



**YOUR
SOLUTIONS**

C O R R O S I V E A P P L I C A T I O N S

User manual
Installation
Operation
Maintenance

*Read before
installing or
operating the
pump unit*

*Keep available
for future
reference*

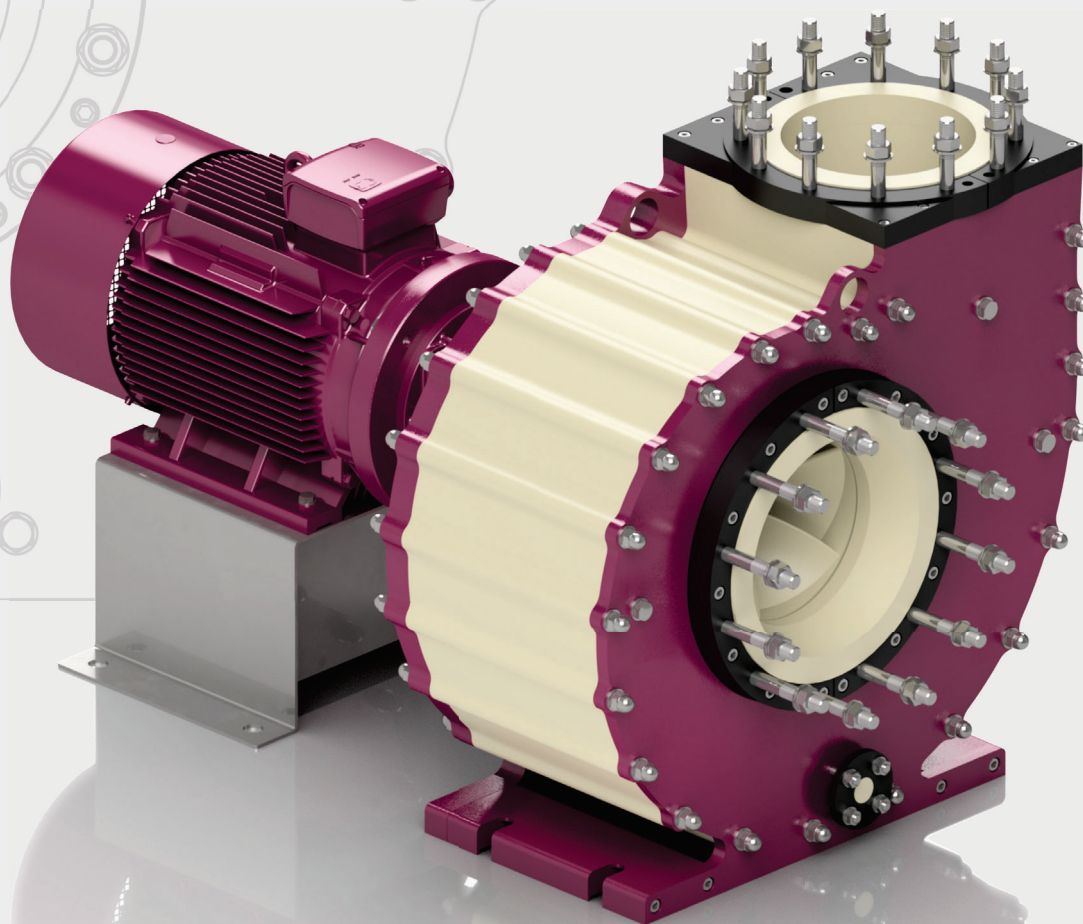

ISO 9001:2015
Certified company



2006/42/EC
Machinery Directive



HXKM-002EN
Translation of the
original instructions

User manual in the original or in different languages should be requested to the manufacturer.

**Horizontal high flow centrifugal pumps
with mechanical seal**

CMK

Index

1.0 GENERAL 3

1.1 EC CONFORMITY DECLARATION	3
1.2 GENERAL INFORMATION	3
1.3 DISCLAIMER AND RIGHTS	3
1.4 DESCRIPTION OF CMK SERIES	3
1.5 PUMP CODE	3
1.6 SERIAL NUMBER	3
1.7 MARKING	3
1.8 CERTIFICATIONS	4
1.9 DOCUMENTATION	4
1.10 WARRANTY	4
1.11 SAFETY	4

2.0 PUMP DESCRIPTION 5

2.1 MAIN PARTS	5
2.2 MAXIMUM OPERATING SPEEDS	6
2.3 MAXIMUM PRESSURES	6
2.4 MINIMUM OPERATING FLOW RATES	6

3.0 TRANSPORT AND STORAGE 6

3.1 PACKING	6
3.2 TRANSPORT, HANDLING AND HOISTING	6
3.3 STORAGE	7

4.0 INSTALLATION 7

4.1 LOCATION OF THE PUMP UNIT	7
4.2 SUPPORT BASEPLATE AND FOUNDATIONS	8
4.3 PIPING	8
4.4 SUCTION PIPING	9
4.5 DISCHARGE PIPING	9
4.6 FILLING PIPING	9
4.7 DRAINAGE PIPING	9
4.8 FITTINGS	10
4.9 CONTROL INSTRUMENTS	10
4.10 FINAL CHECK	10
4.11 CONNECTION OF THE ELECTRIC MOTOR	10
4.12 CONNECTION OF THE INTERNAL COMBUSTION ENGINE	11
4.13 TYPICAL INSTALLATION	12

5.0 OPERATION 16

5.1 DIRECTION OF ROTATION	16
5.2 PRELIMINARY PUMP TESTING	16
5.3 FLUSHING	16
5.4 PRELIMINARY MOTOR TESTING	16
5.5 START-UP	16
5.6 OPERATION	16
5.7 SHUTDOWN	16
5.8 TEMPERATURES	17
5.9 FLOW RANGE	17
5.10 VIBRATION LEVEL	17
5.11 NOISE LEVEL	17

6.0 MAINTENANCE 18

6.1 PREVENTIVE MAINTENANCE	18
6.2 MAINTENANCE INSTRUCTION	18
6.3 DAILY INSPECTION AND MAINTENANCE	18
6.4 SIX-MONTHLY INSPECTION AND MAINTENANCE	18
6.5 EXTRAORDINARY MAINTENANCE	19
6.6 CRYSTALLIZATION OF THE PROCESS LIQUID	19
6.7 DRAINING AND CHANGING THE PROCESS LIQUID	19
6.8 DRY RUN OPERATION	19
6.9 IMPURITIES CONTAINED IN THE PROCESS LIQUID	19
6.10 RECOMMENDED SPARE PARTS	19
6.11 DISPOSAL	19
6.12 RETURNING OF THE PUMP UNIT TO THE MANUFACTURER	20
6.13 DISASSEMBLY OF THE PUMP UNIT	20
6.14 ASSEMBLY OF THE PUMP UNIT	23
6.15 CAUSES OF TROUBLE AND TROUBLESHOOTING	29

7.0 PARTS LIST 30

7.1 SECTIONAL DRAWING AND PARTS LIST	30
7.2 EXPLODED VIEW AND PARTS LIST	32
7.3 MECHANICAL SEAL JRS / JRS1	34
7.4 MECHANICAL SEAL B6E / B6EC / B6EFL / B6EFLC	36
7.5 MECHANICAL SEAL B6EDF / B6EDFC	38

8.0 AUXILIARY COMPONENTS 40

8.1 SYMBOLS LEGEND AND NOTES	40
8.2 FLUSHING SYSTEM FOR SINGLE SEAL: API PLAN 01	40
8.3 FLUSHING SYSTEM FOR SINGLE SEAL: API PLAN 11	40
8.4 FLUSHING SYSTEM FOR SINGLE SEAL: API PLAN 12	40
8.5 FLUSHING SYSTEM FOR SINGLE SEAL: API PLAN 32	41
8.6 FLUSHING SYSTEM FOR DOUBLE SEAL: API PLAN 52	41
8.7 FLUSHING SYSTEM FOR DOUBLE SEAL: API PLAN 53	41
8.8 FLUSHING SYSTEM FOR DOUBLE SEAL: API PLAN 54	42
8.9 FLUSHING SYSTEM FOR DOUBLE SEAL: API PLAN 55	42
8.10 ADHESIVES AND ADDITIONAL INFORMATION	43

1.0 GENERAL

1.1 EC CONFORMITY DECLARATION

Manufacturer:
AFFETTI PUMPS s.r.l.
Via P. Maroncelli, 4
21053 Castellanza (VA) ITALY

The manufacturer declares that the pump unit CMK in the standard designs and supplied with a drive (electric motor or internal combustion engine) guards and baseplate complies with the 2006/42/EC Machinery Directive.

Applied harmonised standards:

- EN ISO 12100:2010 General principles for design
- EN ISO 809:2009 Pumps and pump units for liquids

Conformity to the directives and standards listed above is subject to the condition that the pump unit is used in accordance with the conditions of service contractually agreed, this responsibility belong to the end-user.

Any modification to the pump unit or its use not contractually agreed or not approved in writing by the manufacturer will make null and void this declaration.

The pump unit to which this declaration refers may only be put into operation after they have been installed as specified by the manufacturer and after that the complete system or plant of which these pumps form part complies with the requirements of the Directive 2006/42/EC.

In case of supply of partly completed pump, the purchaser and the user must provide the assembly of the pump unit (pump, drive, guards and baseplate) according the manufacturer's instructions and verify the compliance to the Directive 2006/42/EC before to put the machinery into operation.

1.2 GENERAL INFORMATION

This manual is written to ensure safe operating of the pump unit and its intended use. The equipment must operate in compliance with these instructions in order to guarantee reliability and avoid risks for the user. The user and the operator must follow the national standards and safety regulations in force, even if they have not been mentioned in this manual.

This information must always be kept close to where the pump is installed or attached, if possible, to the pump itself. The user manual must be read, analysed and understood before installing, operating or carrying out any maintenance work on the pump unit. Failure to comply with one or more instructions contained in this manual may cause danger to personnel and will void the manufacturer warranty.

The instructions and information contained in this user manual are only valid for the pump to which the manual is attached. They do not apply to the plant in which the pump unit will be installed.

1.3 DISCLAIMER AND RIGHTS

Information contained in this manual is deemed reliable but the manufacturer declines all liability in the event that, despite all efforts to provide exhaustive and consistent information, the contents of this manual prove to be insufficient. The purchaser and

the user must check the information contained in this instruction manual and contact the manufacturer for any missing information.

All rights reserved. No part of this manual may be reproduced, stored in any type of system or transmitted in any form whatsoever, nor by any means, without prior authorisation from the manufacturer.

The manufacturer reserves the right to make changes to the structure of the pump without updating previous supplies.

1.4 DESCRIPTION OF CMK SERIES

The CMK series has been developed for pumping corrosive liquids. They are intended to be installed horizontally in a suitable plant or system. Special attention has been dedicated to heavy construction, easy access for maintenance and hydraulic efficiency. Each pump is combined with a series of motors of different power ratings and satisfies the most varied needs thanks to an optimum ratio between flow and total head, guaranteeing low energy consumption.

1.5 PUMP CODE

The pump code identifies the pump and construction materials.

Code	Description
CMK	Name of series
250-330	Size of pump
PP	Casing and impeller material
FPM	O-rings material
55 kW	Installed power

TABLE 1.5.1: Identification codes

1.6 SERIAL NUMBER

The serial number is a sequential number used to identify each pump manufactured. It is marked on the pump's tag plate.

1.7 MARKING

The tag plate applied on the pump contains all data required in accordance with the 2006/42 EC Machinery Directive, which also facilitates identification of the pump unit. For any spare part requests, should be provided the data marked on the pump's tag plate and the serial number.

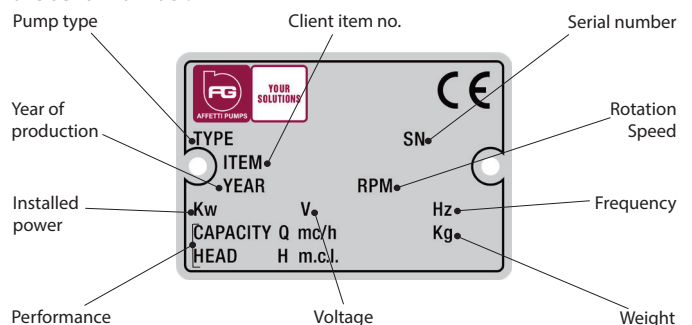

NOTE: The weight indicated on the pump tag-plate refers to the weight of the pump unit (pump, drive and baseplate). Detailed weights of the single parts can be provided by the manufacturer on request.

NOTE: In case of supply of partly completed pump, the weight indicated refers only to the parts provided. For safety reasons, the purchaser and the user must provide the permanently fixing of an additional tag-plate indicating the total weight of the pump unit (pump, drive and baseplate) assembled in accordance with the Directive 2006/42/EC.

1.8 CERTIFICATIONS

Certifications supplied as standard are:

- 2006/42/EC conformity declaration
- Pump data sheet
- Warranty certificate

Certifications available on request are:

- A-weighted sound pressure (at contractual point)
- Certificate of origin
- Certificate of origin for materials
- Functional test without data recording
- Hydrostatic test
- Impeller balancing certificate
- Material conformity certificate
- Performance test with report (Q-H-Na-%)
- Performance test with report (Q-H-Na-%-NPSHr)
- Pump shaft balancing certificate
- Strip down certificate
- Vibration measurement (at contractual point)
- Visual examination and dimensional test

1.9 DOCUMENTATION

The following documentation is attached to the user manual:

- Cross sectional drawing of the pump (on request)
- User manual of the drive

NOTE: The pump manufacturer must be informed in case of total or partial absence of the required documentation.

1.10 WARRANTY

The pump units are guaranteed in so far as they are of our manufacture. Manufacturing or material defects are covered by the warranty unless otherwise agreed (see Warranty certificate), for a period of up to one year from the date of dispatch from our factory and not more than six months from the date of installation. During this period the manufacturer undertakes to substitute and repair free of charge any pump unit found to have been faulty from the start due to manufacturing or material defects. The warranty covers the replacement of faulty parts, not before establish that any damage to the pump are not dependent on external causes, but only and exclusively by manufacturing defects. The manufacturer is not liable for damages caused by dry running, incorrect assembly, foreign bodies entering into the pump, the use of liquids not declared to the pump manufacturer, changes in the duty point (compared to the data submitted at time of order), water hammer, transport (the goods travel at the customer's own risk), and others. The warranty does not cover compensation for direct or indirect damages caused by the pump to objects or persons and to the maintenance operations carried out by the user or by third parties. Unapproved interventions or reparations, product tampering or use of parts or accessories not supplied by the pump manufacturer will void the warranty of the entire pump unit.

In case of reparations or replacements on warranty, the customer or user should ensure the delivery of the pump unit, carefully packed, at the factory of the manufacturer and the consequently withdrawal of the goods taking transport and packaging charges.

The manufacturer liability is void when the customer or the user does not comply with all contractual terms or indication and instructions provided in the user manual.

Manufacturer reparations do not interrupt the period of the warranty. Parts subject to wear are not covered by the warranty.

NOTE: Any intervention on the pump unit during the warranty period must be authorized by the manufacturer.

1.11 SAFETY

All personnel involved in the installation, operation, inspection and maintenance of the pump must be qualified for the job.

If the personnel are not qualified for the job to perform, the customer and the user shall ensure appropriate training. Training can be provided by the manufacturer after prior according and economic quantification.

All original parts and accessories have been designed, tested and assembled to guarantee the quality and continuity of the final product. The use of non-original parts or accessories could affect performance and reliability of the product. Damage or faults generated by improper use, as changing the structure of the pump unit or removing its original components may impair the safety of these products that will not be covered by warranty.

This manual contains specific safety symbols, as described here below. Non-observance of the instructions related to the various symbols may result in the occurrence of a hazardous situation.

 This warning symbol indicates safety measures. Non-observance of these instructions could pose a safety risk for people.

 **CAUTION** This warning symbol indicates safety measures. Non-observance of these instructions could pose a safety risk for people and the operation of equipment and could result in damage to the pump unit.

 **DANGER** This Hazard symbol indicates safety measures regarding electrical parts. Non-observance of these instructions could pose a serious safety risk for people.

NOTE: This symbol indicates important instructions that must be followed.

Some important instructions related to safety are given here below:

 Beware of the process liquid, avoiding any contact.

 The pumps of this series should be used to transfer liquid chemicals. Operators must wear appropriate protective equipment during all procedures of installation, operation and maintenance. Rubber boots, anti-acid overalls and a helmet with a protective visor for the face are the essential devices to prevent contact with the process liquid.

 In the event of leakages of corrosive or hot liquid immediate actions to avoid the any contact, such as the evacuation of the area, must be taken. The corrosive liquid must be removed only by authorized companies in accordance with national laws and regulations.

 Never touch the pump if the process liquid exceeds +70°C. Wait until the pump cools down before performing any work.

 When handling a toxic liquid, ventilate the working area.

 No liquid should be drained directly onto the ground. Install a drain pipe system (including a gate valve) from the drain hole and drain the

liquid in a tank or reservoir chemically resistant according to the laws and regulations related to the application, handling and processing of hazardous liquids before disassembly the pump unit from the piping.

 Do not remove guards and protective devices during the pump operation.

 After maintenance works place and fix again all guards and protective devices. All parts must be assembled before the start-up of the pump.

 Any rotating part should not be freely accessible during the pump unit operation.

 Handle any sharp components with care.

 Do not put hands or fingers inside the holes, openings or windows of the pump unit.

 Do not stand on the pump or use it as support or step.

 Do not remove the end caps from the nozzle of the pump until the installation. Place them again when the pump is removed from the system.

 Any work must be carried out when the pump is not operating. If a switch has been fitted, it must be set to the “zero” (off) position. A warning must be exposed on the control panel: **“Pump under repair: do not start”** and a warning must be exposed on the cables: **“Pump under repair: do not connect”**.

 **CAUTION** Never start the pump without liquid inside the casing.

 **CAUTION** Maintain the gate valves in the suction pipe fully open when the pump is starting or operating.

 **CAUTION** Comply with the limits of flow and use specified in the order confirmation.

 **CAUTION** Prevent the entry of foreign objects into the pump.

 **CAUTION** Avoid any rapid changes in the temperature of liquid.

 **CAUTION** Never choke the piping when the pump is operating.

 **DANGER** Electrical motor and other devices must be installed according to the safety regulations in force.

 **DANGER** If a variable speed drive is used, not exceed the frequency for which the pump has been designed.

 **DANGER** Run the at the specified power supply voltage on the tag plate of the motor.

 **DANGER** Install an earth leakage breaker.

 **DANGER** Arrange grounding.

2.0 PUMP DESCRIPTION

2.1 MAIN PARTS

2.1.1 Casing

The casing is equipped with a volute and the suction inlet and delivery outlet are in an axial or radial position. It has flanged connections according to ISO 7005 / DIN 2501 PN10 standards (according to ANSI B16.5 standards on request). In the lowest area of the casing is provided a hole to allow the drainage of liquid remaining in the pump.

2.1.2 Impeller

The impeller is the semi-open or closed type. Its size depends on the performance required. The blades on the rear side reduce the axial thrust caused by the flow of liquid during the working operation.

2.1.3 Shaft

The shaft transmits to the impeller the rotary motion generated by the drive. It is assembled directly to the drive.

2.1.4 Seal chamber

The gland contains the mechanical seal. For single seals it is provided with a drainage hole in the bottom. The threaded connection must be suitably connected to a drain pipe required to convey any leakage of liquid. For flushed seals it is provided with an inlet port. For double mechanical seals it is provided with two opposite lateral threaded connections to inject and eject the auxiliary liquid.

2.1.5 Mechanical seal

The mechanical seal prevents fluid leaks from the pump. The selection is made at the time of offer according to the pump's operating conditions and compatibility with the process liquid.

 **CAUTION** **The mechanical seal must never be run dry.**

NOTE: The mechanical seal does not require lubrication with oil or grease.

NOTE: The working lengths of mechanical seals are indicated in the chapter 7.

2.1.6 Frame

The heavy construction frame consists of a single piece purposely designed to support the pump and protect the rotating parts.

The frame size or group depends on the pump model as indicated below:

Pump model	Group (Frame)	Pump model	Group (Frame)
250-330	IV	-	-
250-500L	IV	250-500L	IV
300-600H	V	300-600L	V

TABLE 2.1.6.1: Frame sizes or groups.

2.1.7 Baseplate

The baseplate is in electro-welded carbon steel (S235JR) or in sheet metal steel (SS316). On request, the baseplate can be provided with a regulation system to align the pump unit.

 The baseplate is provided (on request) with a drip-pan for pump leakages. The drip-pan has a drain hole that should be connected to a drainage piping with a check valve. Leakages should be conveyed in a chemically resistant reservoir. The leakages level must never exceed the maximum capacity of the drip-pan.

2.1.8 Drive

The motors installed comply with the IEC standards (NEMA on request), have an IP55 protection rating and are built in insulation class F, unless other special requirements apply.

NOTE: On request the pump can be provided with an internal combustion engine.

NOTE: The user manual of the drive is provided with the goods. It has the same importance of the user manual of the pump and should be read and analysed before all operations.

2.2 MAXIMUM OPERATING SPEEDS

Pump model	Max. RPM
All	1150

TABLE 2.2.1: Maximum operating speeds.

2.3 MAXIMUM PRESSURES

The maximum pressure (including the hydrostatic test) is equal to 1.5 times the maximum working pressure at the duty point (specified on the purchase order). Higher factor or different conditions must be agreed with the manufacturer.

 Apply higher pressures than those agreed could pose a safety risk for people and the operation of equipment and could result in damage to property.

NOTE: All fittings and connections assembled must withstand to the maximum pressure of the pump.

2.4 MINIMUM OPERATING FLOW RATES

The minimum continuous flow must be maintained with regard to the pump's best efficiency point (BEP) as indicated in the following table:

Pump model	% BEP	
	700 / 850	950 / 1150
250-330	30%	40%
250-500H / 250-500L	35%	45%
300-600H / 300-600L	40%	50%

TABLE 2.4.1: Minimum operating flow rates (continuous flow).

NOTE: If the flow rate required is less than the minimum flow rate, the plant should be equipped with a by-pass system in order to guarantee the return of excess liquid from the discharge pipe (before the gate valve) to the suction reservoir.

NOTE: The maximum flow value must not exceed 125% of the pump's best efficiency point (BEP).

3.0 TRANSPORT AND STORAGE

3.1 PACKING

The packaging structure and materials are chosen according to shape, dimensions and weight of the good to be shipped.

The following procedure should be followed on receipt of the goods:

1. Check whether the packaging shows any sign of damage that may have occurred during transport.
2. Check that the contents correspond with that specified on the transport document and the order confirmation.
3. Carefully remove the contents from the packaging.

NOTE: The goods must be inspected carefully upon receipt. The manufacturer is not responsible for damage to the pump components during transport. Any damage or deterioration of the pump unit found after the unpacking must be immediately notified to the forwarder. It also needs to inform the pump manufacturer to verify the functionality of the products.

NOTE: For safety reasons some components or accessories may be contained within the main package but packaged separately. Inspect the inside of the case after removing the pump unit.

3.2 TRANSPORT, HANDLING AND HOISTING

The transport is a delicate operation to which particular attention should be paid in order to guarantee later the correct operation of the pump unit. The loading and unloading operations must be carried out considering the shape, the dimensions and the weight of the packaging.

During the lifting operation most fragile parts of the pump (plastic unit and connections) must be free from stresses (tension and torsion). The pump unit must be lying with care, fixed and supported in such a way that is not subject to movement or vibration during transport. The unloading operations at the user's site must be performed with the same precautions observed for the loading phase.

Some instructions for transport, handling and hoisting are provided below:

- Before handling any component check the weight, dimension and the center of gravity (provided on request).
- Always lift the pump unit from the recommended hoisting points (see illustrations 3.2.1).
- Always hoist the pump horizontally, never vertically.
- The ropes or slings must not create an angle greater than 90°.
- The handles provided for hoisting a single component must not be used to hoist the entire unit.
- Do not lift the pump unit using only the eyebolts of the drive.
- If the pump unit needs to be moved after it has been installed, make sure that the pump has been drained.

 Never pass or stop below a hoisted load.

 Never use chains or metallic slings.

 Use an oversized lifting system for the load to be handled.

 No components (including spare parts) must be hoisted without a lifting system (fork vehicles or cranes) if its weight exceeds the maximum allowed for manual handling. Always use a proper

and tested lifting system in good condition. Single component of the pump must be hoisted by connecting lifting system to its rings, eyebolts, threaded holes or terminals. The goods must only be handled by properly trained personnel, in accordance with the relevant regulations in force.

 To correctly use the eyebolts of the pump unit tighten them until they adhere completely to the support surface on which they are assembled making sure that the ring is oriented in the direction of the load; if necessary the user has to use shims to be insert under the base of the eyebolts to orient the ring in the right direction. Check before using each time and at least once a year verify the integrity of the eyebolts and if they have breaks, cracks and are very worn or has deformations replace the eyebolts with new ones.

 Safety and protective devices such as gloves, helmets and safety shoes must be used to protect personnel during goods handling.

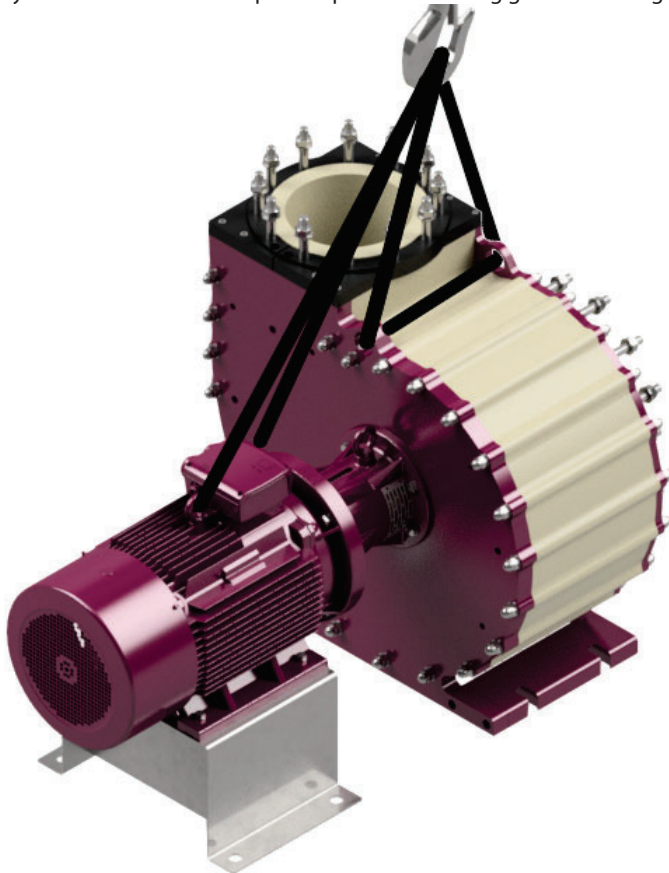



ILLUSTRATION 3.2.1: Handling pump.

3.3 STORAGE

The installation of the pump unit should be done on receipt of goods. Otherwise, the entire group may be stored for up six months in a clean and dry place; far from sources of vibration and radiation, flammable or explosive materials and not exposed to sunlight or heat sources.

 **CAUTION** The pump unit must be stored protected from humidity and dust, and should not be accessible to unauthorized personnel.

 The stored pump after use must not contain any liquid or solid particles. The pump should be internally washed with compatible liquid and the residues drained before storage.

Some general instructions are provided below:

- Store the pump unit indoors in a package. If the pump unit will be stored outdoors, the packaging must be waterproof and prevents the infiltration of humidity.
- Place the stored pump unit horizontally and cover it with a waterproof canvas.
- Place all equipment upon a skid or a block to prevent contact with ground or contaminant surfaces. Support them to prevent distortion or bending.
- Do not place heavy objects on the packaged products.
- Protect the stored pump unit from splashes or corrosive substances.
- Maintain the temperature in the storage area from +5 °C to +35°C. The storage temperature must always be above the freezing point.
- During storage, once a month, rotate the shaft head manually for at least 5 turns in the direction of rotation (via the fan of the drive) to prevent the contact faces from seizing up due to friction.
- Do not remove the end plug on the nozzles of the pump until the installation of the pump unit on the plant.
- Clean the pump thoroughly before install it on the plant, eliminating any foreign bodies that could compromise its correct operation.

 The drive should be storage according to the manufacturer's instructions.

 After a long period of storage elastomeric elements could lose its elastic properties. In this case replace them with new parts.

NOTE: The storage instructions must be also applied to the auxiliary components and spare parts provided by the pump manufacturer.

NOTE: The manufacturer or a representative may carry out, on request, an inspection on the pump unit after a long period of inactivity or before the installation. The inspection will be economically quantified at the time of the request.

NOTE: Damage or malfunction caused by improper storage of goods are not covered by warranty.

4.0 INSTALLATION

Read the user manual carefully before installation. Personnel performing the installation must be aware of all of the information contained herein. Failure to follow these instructions could cause serious damage to the pump unit, which would no longer be covered by the warranty.

4.1 LOCATION OF THE PUMP UNIT

 The follow operations must only be performed by specialized and trained staff.

The pump unit has to be installed in the best possible position to ensure:

- Easy installation of the suction and discharge pipes.
- Easy access for inspection and maintenance operations.
- Proximity to the suction tank or reservoir.
- NPSH available at least 1 meter greater than NPSH required.

 The pump unit must not be installed in areas at risk of fire or earthquake.

! The pump unit installed outdoors must be protected from the rain by a roof.

! Sufficient safety distance must be kept between the pump unit and any passing people. To ensure the safety of the operator or any the positioning of the pump should be performed taking into consideration possible ruptures of the parts or leakages and splashes of corrosive liquid under pressure.

! Before installing the pump unit, make sure that the switch is in the “zero” position (OFF) and disconnect the cables from the power supply to avoid the accidental operation of rotating parts.

NOTE: Install the pump horizontally with the discharge port on the top.

NOTE: The ambient temperature should be between +5 and +35°C and the humidity should not be higher than 85% RH.

NOTE: The site of installation must always be clean, well-ventilated and sufficiently lit (with natural or artificial lighting according to 89/654/EEC).

NOTE: If the pump unit is installed in a raised position, take any measures necessary to prevent it or any of its parts from falling over or down whilst in operation. The pump unit must be securely fastened to a firm baseplate. In addition, the installation place should be provided of facilities allowing the secure access to the pump unit during installation and maintenance works.

4.2 SUPPORT BASEPLATE AND FOUNDATIONS

The support baseplate must be made using suitable materials to guarantee the stability of the pump unit and its surrounding area. Foundations in reinforced concrete laid on solid ground are highly recommended. After positioning the unit horizontally, check the planarity of the structure by a spirit level and fix the baseplate through SS 316 anchor bolts. In case of misalignment between the pump unit and pipes are recommended to use SS 316 shims or the regulation system (if provided by the manufacturer) to even out any differences found.

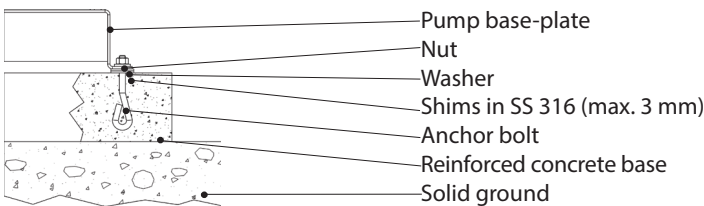

ILLUSTRATION 4.2.1: Example of support baseplate and foundation.

! Before positioning the pump unit, make sure that the foundations are solid, levelled and clean.

! The maximum allowable non-planarity of the structure is 0,2 mm/m.

! The foundation must support the weight of the pump unit and any service loads.

! The walking surfaces should be non-slip material.

NOTE: The pump base-plate must be placed on a floor for all its inner and outer perimeter.

NOTE: The area of the foundations must be greater than the base-plate of the pump.

4.3 PIPING

The design of the pipes has a direct effect on the operation of centrifugal pumps. Particular attention should be paid to the size of the suction tank and the suction and discharge piping.

The suction and discharge pipes, connected to the inlets and outlets of the pump, must not produce excessive or disproportionate loads. Excessively high forces and moments transmitted by the pipes may cause damage to the pump. Suction and discharge piping should be well supported and firmly fastened in place. This operation is essential and compulsory for ensuring correct operation of the pump.

Forces and moments applied to the pump should be maintained as low as possible. The maximum allowable forces and moments to the pump connections are given in the table 4.3.1 and 4.3.2). Higher values must not be applied to the pump.

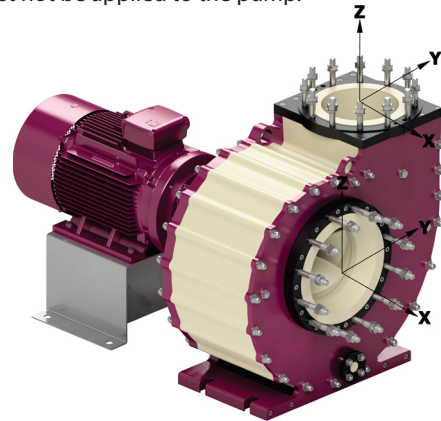

ILLUSTRATION 4.3.1: Forces and Moments

Forces (N) and Moments (N/m) on suction branch								
DN	Fy	Fz	Fx	ΣF	My	Mz	Mx	ΣM
300	5800	5250	6500	10150	2800	3200	3950	5800
350	6800	6100	7550	11850	3550	4150	5050	7400
400	7750	7000	8650	13550	4500	5150	6300	9300

TABLE 4.3.1: Forces (N) and Moments (N/m) on suction branch.
NOTE 1: All values of forces and moments are given for the basic material (Polypropylene) and for temperature of 20°C applied to a new pump unit firmly anchored to a solid ground. For different conditions or materials contact the manufacturer.

NOTE 2: ΣF and ΣM are the vector sums of the forces and moments.

Forces (N) and Moments (N/m) on discharge branch								
DN	Fy	Fz	Fx	ΣF	My	Mz	Mx	ΣM
250	4400	5450	4850	8500	2050	2350	2900	4250
300	5250	6500	5800	10200	2800	3200	3950	5800
350	6100	7600	6800	11900	3550	4150	5050	7400

TABLE 4.3.2: Forces (N) and Moments (N/m) on discharge branch.
NOTE 1: All values of forces and moments are given for the basic material (Polypropylene) and for temperature of 20°C applied to a new pump unit firmly anchored to a solid ground. For different conditions or materials contact the manufacturer.

NOTE 2: ΣF and ΣM are the vector sums of the forces and moments.

 Always check the chemical resistance of the seals and gaskets of the piping to the process liquid.

 Check the parallelism between the pipe and the pump flanges. Forcing and misalignments between the various fittings could produce leakage or even cracks in the most fragile sections of the pipe.

NOTE: The pump must not be used to support the piping.

NOTE: Check that the pump unit is isolated from any external source of vibration. If the pump unit is subject to vibration provide anti-vibration mount.

NOTE: Use full flat gasket with a minimum thickness of 3,2 mm (recommended 5 mm) and hardness of 70 Shore.

4.4 SUCTION PIPING

The correct sizing of the suction pipe is essential. Many problems connected with the operation of centrifugal pumps are caused by incorrect suction conditions.

NOTE: **Size the suction piping considering the pump's NPSH required so that it is at least 1m lower than the plant's NPSH available.**

Some general instructions are provided below:

- The suction piping should be as short and straight as possible and should have an ascending gradient toward the pump in suction conditions or descending gradient of toward the pump in flooded conditions.
- Support the piping using brackets built with or coated in material resistant to contact with the liquid and vapours.
- The speed of the liquid in the suction pipe must not exceed 2 m/s. In case the diameter of the suction pipe is greater than the suction port, install an eccentric reducer before the pump.
- In suction conditions determinate the maximum suction height from the lowest liquid level in the suction tank. Take also into account the viscosity, degree of encrustation and temperature of the liquid.
- Avoid elbows, bottlenecks, sudden reductions or obstructions of any kind. Install only wide radius bends.
- Never fit an elbow directly to the suction port of the pump.
- Avoid any high spots that could create air pockets in the suction pipe.
- Install a gate valve in case of flooded condition of the pump. Maintain the gate valve fully open during the operation. Close it only in case of inspection of the pump.
- Avoid any air infiltration in the suction pipe. Set carefully the joints between the connections.
- Install a properly dimensioned strainer (at least 5 times the nominal diameter) at the end of the suction pipe to prevent infiltrations of foreign matter or solids. The strainer must be periodically cleaned to prevent restriction.
- Maintain the end of the filling and suction pipes in the reservoir always submerged (see plant recommendations on pages 12-15).
- Maintain a minimum distance between the end of suction pipe and the bottom of the suction tank (see plant recommendations on page 12-15). The distance must be more than 0,5 meter in case of solids particles or mud are on the bottom of the tank.
- Fit a baffle walls into the suction tank to prevent infiltrations or vortices in the suction piping.

- Monitor the minimum level of liquid contained in the priming tank (if provided), preferably using a level probe connected to a solenoid valve for filling up any liquid shortages in the suction tank.
- Install the recommended fittings according to the paragraph 4.8.
- Fit the recommended instrumentations according to the paragraph 4.9.

4.5 DISCHARGE PIPING

The discharge pipe should have a check valve and a gate valve on the discharge piping, including performance and temperature monitoring instrumentation.

Some general instructions are provided below:

- Support the piping using brackets built with or coated in material resistant to contact with the liquid and vapours.
- Design the discharge pipe calculating the friction losses, taking also into account the viscosity, degree of encrustation and temperature of the liquid.
- The diameter of the discharge pipe must be selected so that a flow velocity of 3 m/s of liquid is not exceeded. Install an eccentric expansion after the pump if the diameter of the discharge pipe is greater than the port of the pump.
- Avoid elbows, bottlenecks, sudden reductions or obstructions of any kind. Install only wide radius bends.
- Never fit an elbow directly to the discharge port of the pump.
- Avoid any high spots that could create air pockets in the discharge pipe.
- Install an air vent piping between the pump and the check valve. The end of the pipe should be open to the atmosphere.
- Fit a drainage line to remove the process liquid after every stoppage.
- Install a flushing system to wash the pump before maintenance works.
- Install the recommended fittings according to the paragraph 4.8.
- Fit the recommended instrumentations according to the paragraph 4.9.

4.6 FILLING PIPING

A system should be used to fill the suction pipe and the pump installed in suction conditions with the required amount of liquid before the start-up. The filling system should have a gate valve to isolate the pump and a strainer before the filling port (see plant recommendations on page 12-15).

 The gate valve should be maintained closed during the operation.

NOTE: The strainer should be cleaned periodically.

 Fluid leakages may occur during routine cleaning or replacement of the filter. These operations must be carried out when the pump is not in operation and using appropriate safety equipment.

4.7 DRAINAGE PIPING

The manufacturer provides a drain hole in the lowest part of the casing or the dip-tray (supplied on request), complete with gaskets and plug. It is the user responsibility to connect a drain pipe (not provided by the pump manufacturer) that will convey the liquid from the casing (after the shutdown) or the drip-tray (in case of leakages) to a chemically-resistant container. The drain line must include a check valve for the pump isolation (see the follow illustration or plant recommendations on page 12-15).

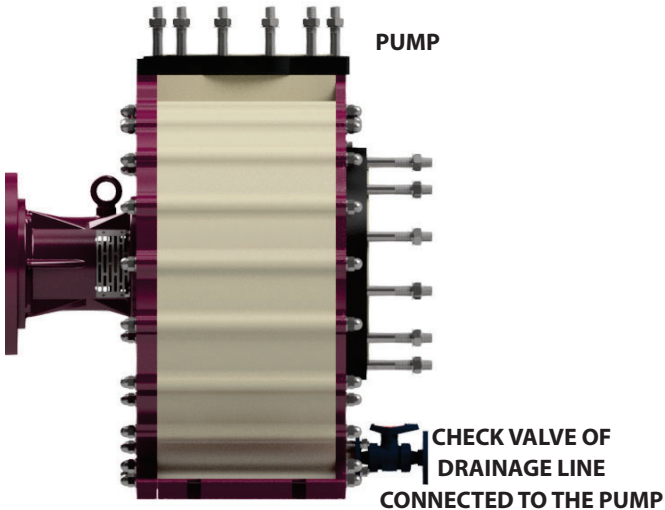

 The drainage piping and fittings should be made of the same material as the connections on the pump.

 The gate valve should be maintained closed during the operation.

NOTE: The drainage hole in the casing is provided as standard, while the drip-pan in the baseplate is provided on request.

4.8 FITTINGS

To guarantee correct operation in safety conditions, the piping should be equipped with the following fittings:

Recommended fittings		
Fitting	Use	Location
Bracket	To support the pipe.	All piping lines.
Strainer	To reduce the quantity of solid particles.	At the end of the suction pipe.
Eccentric reducer	To avoid air pockets.	Before the suction port.
Gate valve	To isolate the pump in case of inspection.	In the suction line.
Flow conditioner	To minimize swirl and turbulence.	In the suction piping, after the gate valve and at least 5 DN from the suction port.
Strainer	To reduce the quantity of solid particles.	After the gate valve and before the filling port.
Gate valve	To isolate the pump during the operation.	In the filling line.
Gate valve	To isolate the pump in case of inspection.	In the drainage line.
Eccentric expansion	To avoid air pockets.	After the discharge port.
Check valve	To protect the pump from water hammer and to avoid the emptying of the discharge pipe after shutdown.	In the discharge line between the pump and the gate valve.

Gate valve	To regulate the pump performance.	After the check valve.
Gate valve	To exclude the air during the priming process.	In the air vent piping.

TABLE 4.8.1: Recommended fittings in the piping.

 Carefully follow the manufacturer's use and installation instructions for all of the fittings.

NOTE: In order to reduce the pressure losses, the internal diameter of fittings and piping should be the same.

4.9 CONTROL INSTRUMENTS

To guarantee correct operation, the piping should be equipped with the following instruments:

Recommended instrumentation		
Instrument	Use	Location
Minimum level probe	To verify the reaching of the minimum level of liquid.	Into the suction tank.
Vacuum gauge	To verify the suction pressure in the suction pipe.	Twice the diameter of the suction port far from the pump.
Thermometer	To check the temperature of the liquid.	In the suction line.
Thermometer	To check the temperature of the liquid.	In the discharge line.
Pressure gauge	To measure the operating pressure.	Twice the diameter of the discharge port far from the pump and before the check valve.
Flow meter	To measure the operating flow.	After the gate valve in discharge line.
Load monitor	To prevent dry running.	Connected to the motor.
Switch (ON/OFF)	To start and stop the pump.	Control panel.
Emergency switch	To stop the operation of the pump in case of failure.	Control panel.
Wattmeter or Ampere-meter	To monitor power absorption.	Control panel.

TABLE 4.9.1: Recommended control instruments in the piping.

 Carefully follow the manufacturer's use and installation instructions for all of the auxiliary control instruments.

4.10 FINAL CHECK

1. Check the screws tightening of the pump unit.
2. Check that the protective caps have been removed from the suction and discharge ports of the pump.
3. Check the parallelism between the pipes flanges and the pump flanges.
4. Check the tightness of the suction and discharge flanges.

4.11 CONNECTION OF THE ELECTRIC MOTOR

 **DANGER** All electrical connections must be made by a quali-

qualified electrician in accordance with EN 60204-1. National or local regulations in force must be observed.



Avoid any electrical, hydraulic or mechanical overloading.

Operations to be performed before starting the pump unit:

- Check that the drive has been connected in compliance with the manufacturer's instructions.
- Check that the earthing connection complies with local regulations.
- Check the tag plate on the motor to ensure that the power supply is correct.
- Check the electric motor has been installed at room temperature, avoiding damp and dusty environments.
- Check the bottom part of the motor is sufficiently free, in proportion to the size of the motor to ensure free air circulation, essential for cooling.
- Install a switch (ON/OFF) and an emergency switch according to the regulation in force.
- Install a soft-start or inverter for motors larger than 11 kW.



If the pump is installed outdoor, waterproof the wiring to protect the electrical connections from rainwater.

NOTE: An alarm system (visual and audio) must be fitted to alert the user in case of failure of the energy source or the electric motor.

Three phase motors can be connected "Star" or "Delta". Star connection is obtained by connecting together the terminals W2, U2, V2 and supplying the terminals U1, V1, W1. Delta connection is obtained by connecting the end of a phase with the beginning of the following one.

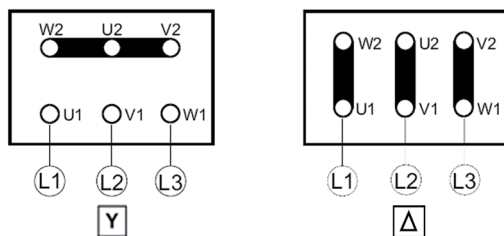

ILLUSTRATION 4.11.1: Electrical connections of the motor.

4.12 CONNECTION OF THE INTERNAL COMBUSTION ENGINE

The user manual for the combustion engine is supplied with the pump. The user should read the instructions carefully and get to know the operations described. By not doing so he may place at risk his own health and safety and that of anyone else in the vicinity of the pump unit. If the engine manual has not been provided, contact the manufacturer immediately.



The responsibility to provide protections for the hot parts of the pump unit belong to the user.

Some important instructions are given here below:

- Unless otherwise specified, the fuel to be used is DIESEL. Never use other liquids or fuels.
- Before starting the engine check the level of the oil and the cooling liquid in the radiator.
- Check that the internal combustion engine rotates in the same direction as the pump.
- Every 350 working hours, check that the bolts for the pump are tight.

Some important instructions related to safety are given here below:

- The engine may be used or mounted on a pump unit only by personnel suitably trained in its operation and aware of the dangers involved. This is particularly true for standard and, above all, special maintenance work. For special maintenance contact personnel trained specifically by the manufacturer.
- The manufacturer declines all responsibility for accidents or for failure to comply with the requirements of law if changes are made to the engine's functional parameters or to the fuel flow rate adjustments and speed of rotation, if seals are removed, or if parts not described in the operating and maintenance manual are removed and reassembled by unauthorized personnel.
- Do not start the pump unit in closed or poorly ventilated environments. The internal combustion process generates carbon monoxide, an odourless and highly toxic gas, so spending too long a time in an environment where the engine discharges its exhaust products freely can lead to loss of consciousness and even death.
- The engine may not be used in environments containing flammable materials, explosive atmospheres or easily combustible powders.
- To prevent the risk of fire, keep the pump unit at a distance of at least one metre from buildings or other machinery.
- Fuel is flammable, so the tank must be filled only when the engine is turned off. Dry carefully any fuel that may have spilled, remove the fuel container and any cloths soaked in fuel or oil, check that any sound-absorbing panels made of porous material are not soaked with fuel or oil, and make sure that the ground on which the pump unit is located has not absorbed fuel or oil.
- During operation the surface of the engine reaches temperatures that may be dangerous. Avoid in particular all contact with the exhaust system.
- Before carrying out any work on the engine, turn it off and allow it to cool down. Do not perform any operation while the engine is running.
- Fuel vapours are highly toxic, so fill up only in the open air or in well ventilated environments.
- To prevent accidental starting remove the ignition key of the engine after the shut-off of the pump.



All of the safety instructions are contained in the engine user manual.

4.12.1 Starting the engine

Insert the ignition key, turning it partially to the right until the LEDs switch on. When the yellow LED switches off, turn the key further to the right until the engine starts. Allow the engine to idle for at least 15 minutes, keeping the accelerator lever fully to the right then, very gradually, move the lever to the left until the required performance is reached and secure it there by tightening the knob on the control support. If the pump's flow rate and head values correspond to the engine's maximum RPM, secure the lever in position using the safety pin.

4.12.2 Removing the engine's hood (if provided)



To protect the health of the maintenance operator, the hood should only be removed when the engine is switched off and cold.













The removal procedure is as follows:

1. If there is an outside pipe connected to the end of the silencer, remove it.
2. Unhook the hooks on the side of the hood.
3. Attach slings to the ringbolt in the upper part of the hood.
4. Lift the hood vertically.

4.13 TYPICAL INSTALLATION

The following is a list of fittings, instruments or indications to be applied in the plant as shown in the examples on pages 13-15.



NOTE: The warning symbol  indicates the equipment and fittings needed for safety requirements.



No.	Description
DN	The diameter of the port of the pump.
DN1	The diameter of the pipe.
A	The minimum distance between the end of suction pipe and the bottom of the tank or reservoir.
B	The minimum submergence of liquid of the suction pipe into the tank or reservoir.
C	The minimum distance between the pipes and the walls of the tank or reservoir.
E	The minimum distance between the suction pipe and the filling pipe in the reservoir.
01	SUCTION PIPE conveys liquid to the pump. In suction conditions, it should be as short and straight as possible and have an ascending gradient toward the pump while in flooded conditions it should have a descending gradient toward the pump. The flow velocity should not be higher than 2 m/s.
02	 BRACKET supports the piping preventing excessive loads on the branches of the pump. It should be built with or coated in material resistant to contact with the liquid and vapours.
03	 DRAINAGE PIPE conveys the liquid evacuated from the pump to the reservoir. The end of the pipe should be open to the atmosphere. It is required a gate valve.
04	BY-PASS ensures the pump's minimum flow rate is maintained. It conveys liquid to the reservoir or the suction piping.
05	SUBMERGED TERMINAL is required for the suction pipe and filling pipe in the reservoir to prevent the formation of vortices.
06	WIDE RADIUS BEND has lower pressure losses compared with tight radius bends and prevents the formation of air pockets.
07	 GATE VALVE isolates the pump from the piping.
08	STRAINER properly dimensioned (at least 5 times the nominal diameter) reduces the concentration of solid particles in the process liquid.
09	DRAINAGE PORT is the terminal of the pump that allows the evacuation of liquid.
10	FOOT VALVE makes it possible to operate in suction conditions.
11	ECCENTRIC REDUCER prevents the formation of air pockets.
12	VACUUM GAUGE measures the suction pressure.
13	SUCTION PORT is the terminal of the pump that allows entry of the liquid into the casing. It is connected to the suction piping.
14	FILLING PORT is the terminal in the discharge piping that allows the liquid filling of the pump and suction piping.
15	DISCHARGE PORT is the terminal of the pump that allows the exit of the liquid. It is connected to the discharge piping.
16	DISCHARGE PIPE conveys the process liquid to a reservoir. The flow velocity should not be higher than 3 m/s.
17	ECCENTRIC EXPANSION prevents the formation of air pockets.
18	PRESSURE GAUGE allows to check the working pressure.
19	 CHECK VALVE protects the pump from water hammer and avoids the emptying of the discharge pipe after shutdown.
20	GATE VALVE (on the discharge pipe) permits to regulate the performance of the pump.
21	FLOW METER allows to check the amount of liquid.
22	FILLING PIPE conveys the liquid to the suction tank or reservoir.
23	 REINFORCED CONCRETE BASEPLATE is required to guarantee stability to the pump.
24	 SOLID GROUND is required to guarantee stability to the pump.
25	EXTERNAL FLUSHING SYSTEM is used to flush or wash the mechanical seal with liquid from an external source.
26	 LOAD MONITOR is used to prevent the dry running of the pump.
27	BAFFLE WALL prevents air or vortices from entering in the suction pipe.
28	 LEVEL PROBE is used to monitor the minimum and maximum level of liquid.
29	PLUG FOR PROBE is used to apply an external level probe.
30	SOLENOID VALVE is used for filling the self-priming tank.
31	PLUG FOR PROBE is provided for the use of an internal level probe and monitoring the minimum and maximum levels in the tank or reservoir.
32	PUMP transfers the liquid from a reservoir to another.
33	SELF-PRIMING TANK (provided on request) permits to operate above the level of the liquid inside the suction reservoir.
34	FLOW CONDITIONER minimizes swirl and turbulence in the suction piping.
35	VENT, installed on highest point, allows the evacuation of the air or gas inside the piping or self-priming tank.
36	 POWER SWITCH (ON/OFF) starts or stops the pump without activating or interrupting the other functions of the plant.
37	 EMERGENCY SWITCH, installed closed to the machinery, stops the operation of the pump in case of failure. It should be used ONLY if the discharge pipe includes a non-return device. It should be in accordance with the requirements of EN ISO 13850.
38	 WATTMETER/ AMPERE-METER monitors power absorption.
39	 ALARM SYSTEM warns the user in case of fault of power supply or electric motor, absence of liquid in the suction piping or fault of auxiliary flushing.

GENERAL NOTES:

- The sketches are illustrative. The recommendations refer to a general installation and some information may be missing.
- All information shown are to be considered useful for the proper functioning of the pump and not for the plant.
- Information contained in these sketches are deemed reliable. The manufacturer shall not be held responsible in the event that, despite their efforts to supply exhaustive and consistent information, the contents prove to be insufficient. The purchaser/user must check the information contained in this sketch.
- Unless otherwise indicated the number of fittings (including brackets) and instruments and their position in the sketches are illustrative.

4.13.1 Installation in suction conditions

-  Before the first start-up fill completely the suction pipe.
-  Never increase the suction height without the approval of the pump manufacturer. Maintain the working conditions indicated on the order confirmation or in the data-sheet.
-  Suction and discharge piping must be tested hydraulically in accordance with the safety regulations before installing the pump.

-  The suction piping must be resistant to vacuum conditions.
-  Check the cleaning of the foot valve periodically. Solid particles or encrustations could compromise correct operation.
-  The emergency switch must be used ONLY if the discharge pipe includes a non-return device.

NOTE: The installation in suction conditions must be authorized by the pump manufacturer.

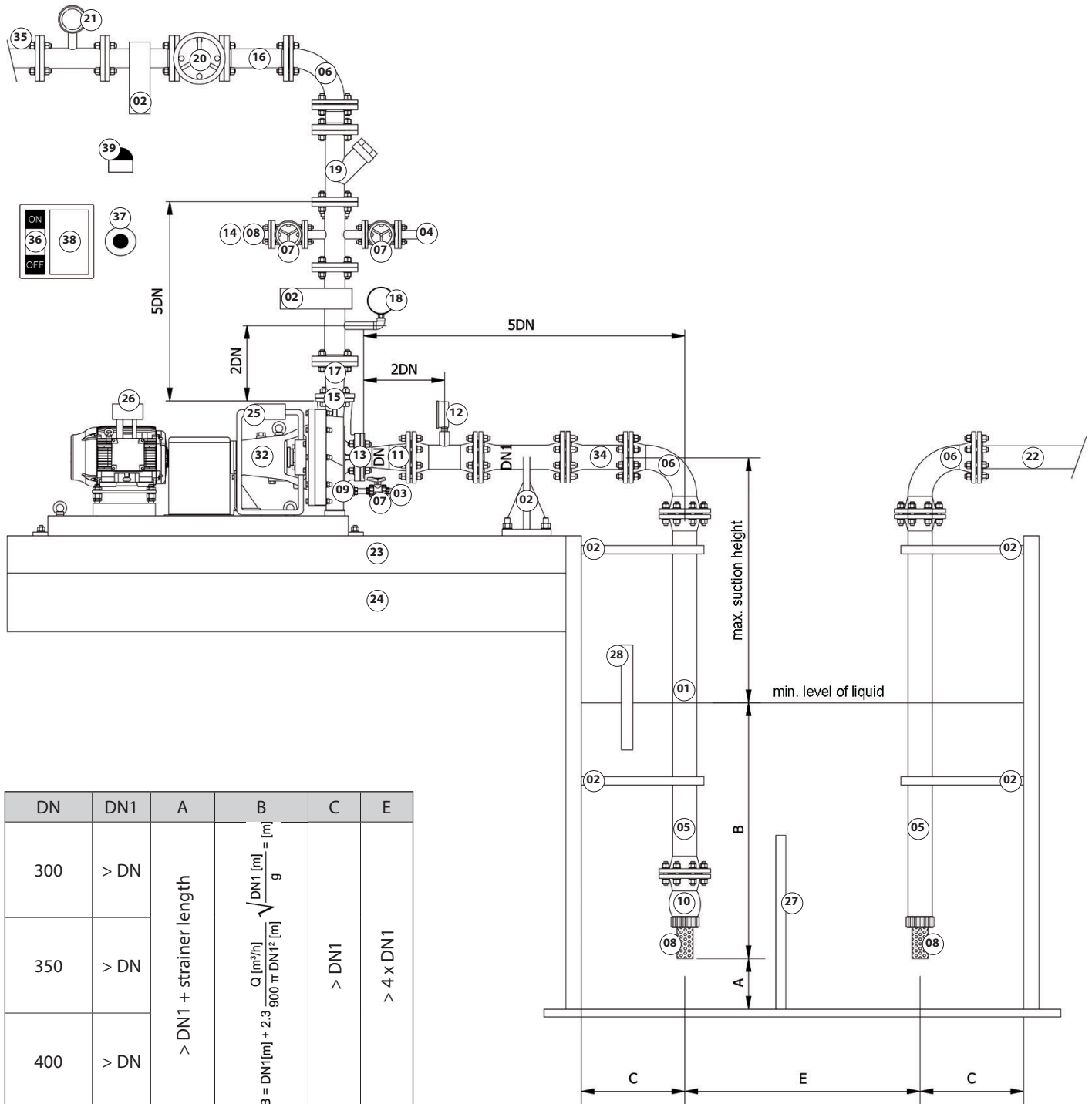

4.13.2 Installation in suction conditions with self-priming tank.

! Never increase the suction height without the approval of the pump manufacturer. Maintain the working conditions indicated on the order confirmation or in the data-sheet.

! Suction and discharge piping must be tested hydraulically in accordance with the safety regulations before installing the pump.

! Never reduce the capacity of the self-priming tank.

! Fill the self-priming tank until reaching the maximum level of liquid before starting the pump.

! Monitor the minimum level of liquid in the self-priming tank during the operation.

! Drain completely the self-priming tank before maintenance.

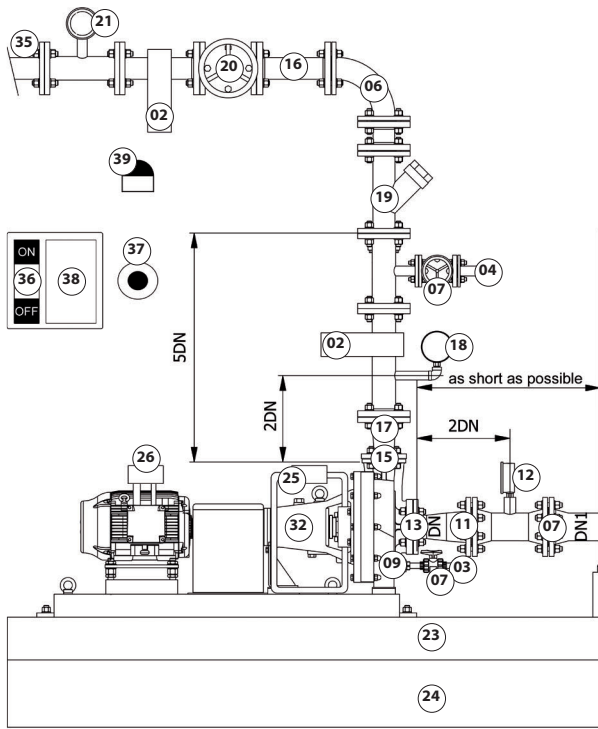

DN	DN1	A	B	C	E
300	> DN	> DN1 + strainer length	$\sqrt{\frac{DN1 [m]}{g}}$		
350	> DN		$\frac{Q [m^3/h]}{9000 \pi DN1^2 [m]}$	> DN1	
400	> DN		$B = DN1 [m] + 2.3$		> 4 x DN1

! The solenoid valve should be connected to the probes inside self-priming tank and should be open when the liquid reaches the minimum level and closed when the self-priming tank is full (even during the operation).

! Check the vacuum pressure in the suction piping is not higher than vacuum resistance of the self-priming tank.

! The suction piping must be resistant to vacuum conditions.

! Forces and moments should not be applied to the nozzle of the self-priming tank. Use brackets.

! The emergency switch must be used ONLY if the discharge pipe includes a non-return device.

NOTE: The installation of self-priming tank must be authorized by the pump manufacturer.

NOTE: It is recommended to use a common base for the pump and the self-priming tank.

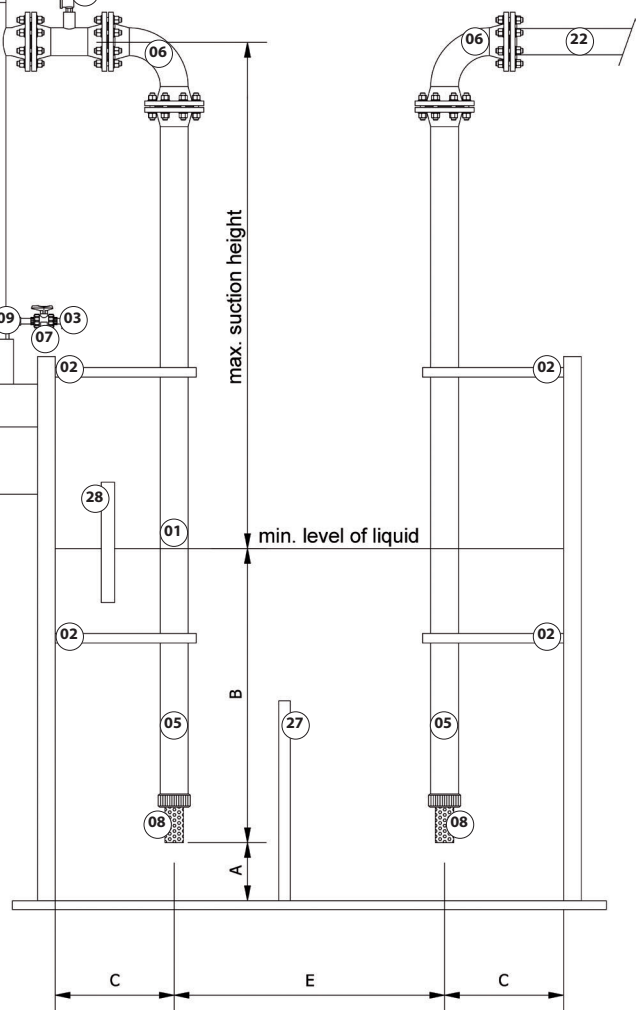

4.13.3 Installation in flooded conditions.

Suction and discharge piping must be tested hydraulically in accordance with the safety regulations before installing the pump.

The emergency switch must be used ONLY if the discharge pipe includes a non-return device.

NOTE: The minimum distance between the pump and gate valve in the suction pipe should be not less than 5 times the diameter of the suction port.

NOTE: The minimum length of the straight suction pipe should be not less than 10 times the diameter of the suction port.

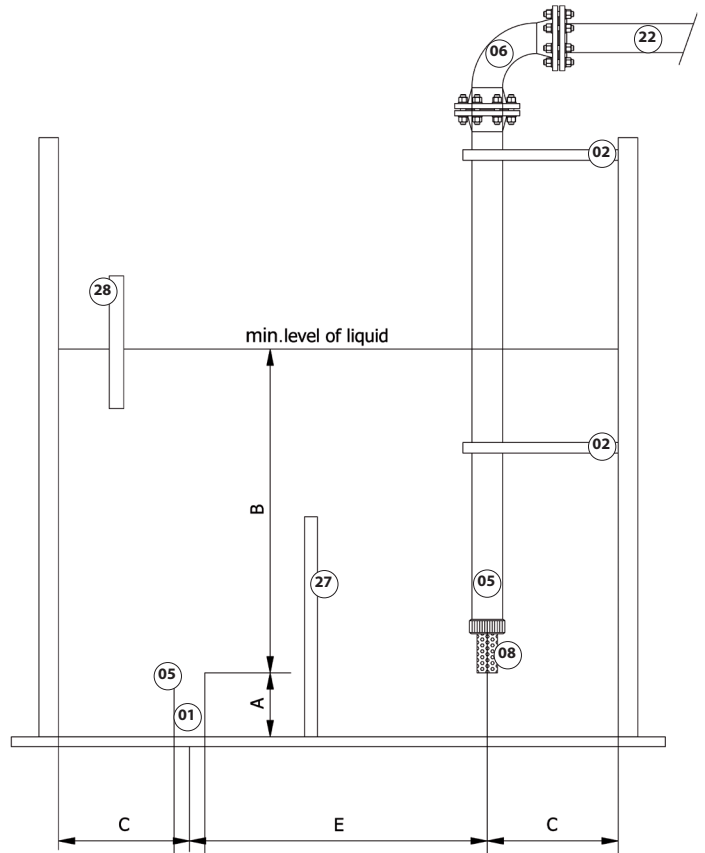
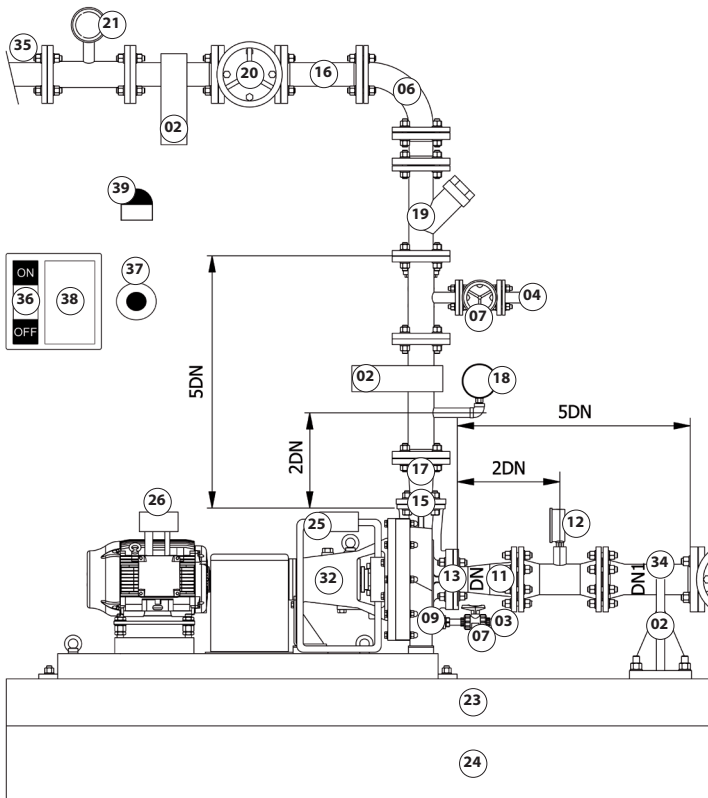

DN	DN1	A	B	C	E
300	> DN	> DN1 + strainer length	$B = DN1[m] + 2.3 \frac{Q [m^3/h]}{900 \pi DN1^2 [m]} \sqrt{\frac{DN1 [m]}{g}} = [m]$	> DN1	> 4 x DN1
350	> DN				
400	> DN				

5.0 OPERATION



The operators should be equipped with appropriate equipment during all operations of this chapter. Rubber boots, anti-acid overalls and a helmet with a protective visor for the face are essential requirements. The pump unit is equipped with rotating parts. It is strictly prohibited to insert fingers or other parts of the body into the orifices and various openings during operation. The follow operations must be performed by skilled staff.

5.1 DIRECTION OF ROTATION

The direction of rotation should be checked before the start-up. The direction of rotation is indicated, in permanent form, on the pump unit; clockwise looking from the motor to the pump.



To ensure the correct direction of rotation is essential to use a phase-meter in order to identify the phases and the colours of the cables.



The pump should never run in the reverse direction of rotation.

NOTE:

The arrows indicating the direction of rotation should always be clean and visible.



After maintenance works direction of rotation should be checked again.

5.2 PRELIMINARY PUMP TESTING

Before the start-up, manually rotate the pump shaft in the direction of rotation by the fan of the motor to make sure that it rotates freely and is free of friction or obstructions. The operation must be performed with electric cables disconnected from the terminal board.

5.3 FLUSHING

If a mechanical seal with external flushing is used, make sure the valve or tap is open before operating the pump and that the instructions given in the chapter 8 concerning quantity, pressure and compatibility of the flushing liquid are complied with.

NOTE:

The threaded connections of the external flushing should be in the same material of the threaded connections of the pump.

5.4 PRELIMINARY MOTOR TESTING

Check all of the electrical connections (see paragraph 4.11) and the direction of rotation (see paragraph 5.1) before the start-up of the pump.

5.5 START-UP

Before starting the pump the following steps should be performed:

1. Check the direction of rotation of the motor (refer to the arrow marked on the pump unit).
2. Check the tightening of the screws and correct connection of the suction and discharge pipes.
3. Check and flush the suction piping to remove any solid or foreign bodies.
4. Close the drainage valve.
5. Open the external mechanical seal flushing device (if provided). Quantities and operating pressure values related to flushing are specified in the chapter 8.
6. Fully open the gate valve on the suction piping. In suction condi-

tions fill the pump and the suction pipe completely

7. Check that the foot valve (if fitted) is operating correctly.
8. Turn the pump on using the power switch.
9. Open gradually the gate valve in the discharge pipe (start from 10%).
10. Adjust the duty point regulating gradually the gate valve (discharge pipe).
11. Check the absorption values of the pump unit referring to those marked on the tag plate of the drive and make sure that those values (absorbed power in kW or intensity in amperes) are not exceeded.

NOTE:

The pump must never run dry.

NOTE:

Clean the inside of the pump before the start-up procedure of a inactive or repaired unit.

NOTE:

Do not use the suction valve to adjust the flow. The suction valve must always be kept open during operation.

NOTE:

Do not open excessively the discharge valve if it will cause the over-load of the motor. Regulate the discharge valve according to the duty point and amperage.

NOTE:

Alternate operation of the pump in use with the stand-by pump at weekly intervals.

5.6 OPERATION

Attention should be paid to the following warnings during the pump's operation:

- It is prohibited to work on the pump unit when it is in operation.
- It is prohibited to carry out any work on the drive when connected to the electric power supply.
- Prevent people or things coming into contact with hot parts of the pump unit.
- Make sure that the pump unit does not vibrate and is not excessively noisy (see paragraphs 5.10 - 5.11).



Check during the operation there are not increases in temperature.



The pump unit must never operate with one or some parts damaged. In the event of a fault, turn the pump off, investigate the cause (see paragraph 6.15) and replace any damaged parts.

NOTE:

The pump must never run dry.

NOTE:

During the operation check the discharge pressure do not exceed the allowable limit (see paragraph 2.3).

NOTE:

The pump should not operate more than 1 minute with the discharge valve fully closed.



Stop the pump in case of cavitation.

5.7 SHUTDOWN

Close the discharge valve (slowly to prevent water hammer) until reaching the 10% of the flow rate. Turn off the power switch and later close completely the discharge valve. Later close the valve of the external flushing (if provided).

 When the pump is stopped without a non-return device on the discharge pipe the liquid could flow back through the pump to the suction source.

NOTE: Start and stop the pump frequently will damage the pump parts early.

NOTE: Do not use a solenoid valve to stop the pump unit.

NOTE: After stopping drain completely the liquid inside the pump.

NOTE: Operation of the inactive pump should be checked on a regular basis.

NOTE: If the pump remains inactive for a long period of time, rotate the pump shaft (via by the fan of the drive) at least 5 turns every months. See paragraph 3.3.

5.8 TEMPERATURES

The working temperature of the pump is indicated in the data sheet and in the order confirmation.

NOTE: The temperatures limits may vary changing the process liquid or its concentration. In order to know the temperature limit for the process liquid contact the pump manufacturer.

 If the operating temperature exceeds 60°C the pump must carry a warning notice to alert personnel working in the area.

 The personnel working close the pump unit must avoid any contact with the hot parts.

5.9 FLOW RANGE

The selection of the type of pump, impeller and motor is made at the time of the offer based on data provided by the customer related to flow rate and head. The user should strictly observe the operating conditions mentioned on the data sheet, especially related to the data concerning the duty point for which the pump was designed. Any change in the duty point of the pump must be approved by the manufacturer.

5.10 VIBRATION LEVEL

Measurement of vibration performed at regular intervals, compared against the values provided by the manufacturer measured during the production test, will highlight any changes in the operating conditions, wear or imbalance of the rotating parts, installation conditions that do not meet the requirements for correct assembly of the pump to the plant or a general state of disrepair of the whole system.

Working condition	Max. vibration level		
	Motor ≤ 7,5 kW	Motor ≤ 30 kW	Motor > 30 kW
Normal	3 mm/s	4,5 mm/s	6 mm/s

TABLE 5.10.1: Vibration level.

Note: the limits above are for new pump unit provided entirely by the manufacturers and carefully anchored in accordance with the instructions given in this manual. Used pump unit may have values of vibration exceeding the limits.

 Continuous monitoring of vibration level and installation of an alarm system set on the limits indicated in the Table 5.10.1 is recommended.

NOTE: The installation of anti-vibration mounts is recommended.

5.11 NOISE LEVEL

Generally the pump unit does not exceed the 80 dB. However, the noise level could increase due a sum of factors, as the duty point, size of motor, type and material of pipeworks and the structure of the building.

Approximate values are provided below:

Motor nominal power [kW]	Noise level in dB(A)			
	700 RPM	850 RPM	950 RPM	1150 RPM
5.5	65	-	-	-
7.5	66	-	-	-
11	68	-	-	-
15	69	70	-	-
18.5	70	70.5	-	-
22	71	72	-	-
30	72	73	78	-
37	73	74	79	-
45	74	75	80	-
55	75	76	80.5	81.5
75	79	77	81	82
90	76	77.5	82	83
110	77	78	82.5	83.5
160	79	80	84	85
200	80	81	85	86

TABLE 5.11.1: Pump unit's sound pressure.

NOTE: The noise values were measured during operation of the pump driven by an electric motor, pumping water at ambient temperature, cavitation free, at the best efficiency point in our test room. Operational factors such as the flow rate, type of pipework and acoustics of the building can increase the pump's sound pressure. The values specified are therefore subject to a tolerance of +5 dBA and are not guaranteed.

 Acoustic emissions should be lower than the maximum levels permitted by local regulations. If the noise level exceeds the safety values, some action that can be taken to protect the health of personnel exposed to sound pressure generated by the pump are indicated here below:

Sound pressure	Action to be taken
Less than 70 dB	No particular action
Greater than 70 dB	Provide personnel working close to the pump with personal protective equipment.
Greater than 80 dB	Signs must be put up at the entrance to and within the area warning that it is a hazardous area due to the high sound pressure level. The pump unit must be equipped with a soundproof covering. Anti-noise headphones must be worn.

TABLE 5.11.2: Actions to protect the health of the personnel.

 If the pump is driven by an internal combustion engine the noise level may exceed 80 dB. If this is the case, the pump unit should be provided with a soundproof covering and personnel must use PPE to protect them from the noise.



Excessive noise from the motor could be a sign that the bearings are worn and excessive noise from the pump could be a sign of cavitation (booming sound, as if the process liquid contains gravel).

6.0 MAINTENANCE



The operators should be equipped with appropriate equipment during all operations of maintenance. Rubber boots, anti-acid overalls and a helmet with a protective visor for the face are essential requirements. It is strictly prohibited to insert fingers or other parts of the body into the orifices and various openings. The pump unit contains moving parts. These operations must be performed by skilled staff.

6.1 PREVENTIVE MAINTENANCE

Check the characteristics of the process liquid (temperature, specific gravity and chemical composition). Check that the flow rate and pressure values comply with the design values and that they have not been subject to change. Make sure that control instruments are fully efficient and they always receive the right signals.

6.2 MAINTENANCE INSTRUCTION

Some instructions for the safety of personnel performing maintenance on the pump unit are given here below:



Before carry out any maintenance work should be analysed the safety data sheet of the process liquid.



All maintenance operations must be carried out in areas previously allocated for this purpose, outside hazardous areas.



For loads greater than the manual handling (including spare parts) use a suitable, type-tested hoisting system that is in good condition connected to rings, eyebolts, holes or threaded terminals of the part to lift. Goods must only be handled by suitably trained personnel, according to the relevant regulations in force.



Check before using each time and at least once a year verify the integrity of the eyebolts and if they have breaks, cracks and are very worn or has deformations replace the eyebolts with new ones.



If the lighting (natural or artificial) is not sufficient the inspection and all maintenance operations should be performed using portable lamps.



Any work must be carried out when the pump is not operating. If a switch has been fitted, it must be set to the "zero" (off) position. A warning must be exposed on the control panel: **"Pump under repair: do not start"** and a warning must be exposed on the cables: **"Pump under repair: do not connect"**.



Never touch the pump if the process liquid exceeds +70°C. Wait until the pump cools down before performing any work.



If the process liquid is hazardous take appropriate safety pre-

cautions when performing maintenance work, in accordance with the regulations in force.



Never spray water or washing liquid on hot parts or components as it could cause thermal shocks.



Never spray air or liquids on the skin or towards other people.



Avoid that during the washing or cleaning of the pump unit the liquid leaking inside the terminal box of the electric motor.

NOTE:

Replace gaskets and O-rings each time the pump is disassembled.

NOTE:

Only on completion of all maintenance works, repeat the start-up procedure indicated in the paragraph 5.5.

6.3 DAILY INSPECTION AND MAINTENANCE

Daily monitoring during operation will ensure immediate action can be taken in the event of malfunction.

Inspect the pump unit every time it is used:

1. Check the noise level, vibration, temperature and performance.
2. Check that there are no unexpected leakages of liquid.
3. Make sure that the external flushing pressure for the mechanical seal (if provided) complies with the values indicated in chapter 8.
4. Make sure the pump never operates without liquid.
5. Check the drip-pan of baseplate (if provided) is not full of liquid. In this case, open the valve and empty the drip-pan.
6. Always make sure that the pump unit is properly fastened, checking that the screws are tightened correctly.

6.4 SIX-MONTHLY INSPECTION AND MAINTENANCE

Inspect the pump every six months irrespective of whether it has been used or not.

The six-monthly maintenance procedure is as follows:

1. Disconnect the electrical part.
2. Drain the casing of the pump.
3. Wash the pump, checking the compatibility of cleaning products used with residues of the process liquid. Never use flammable solvents to clean the parts.
4. Disassembly the pump unit (see paragraph 6.13).
5. Check the condition of the mechanical seal.
6. Check if the wet parts are damaged or worn.
7. Check if there are cavitation traces.
8. Replace gaskets and O-rings.
9. If the liquid contains solid particles, check that the suction filter and the foot valve (in suction conditions) are clean.
10. Check the condition of the bolts used to fasten the baseplate and foundation (see paragraph 4.2).
11. Assembly the pump unit (see paragraph 6.14).
12. Make sure that the pump is properly fastened, checking that all screws are tightened correctly.
13. Start-up the pump (see paragraph 5.5).

If a fault is found, replace the damaged or worn parts or according to the manufacturer send back the pump to repair (see paragraph 6.12).



If the pump is used on fluids with solids particles or high temperature may be requested an earlier inspection and maintenance work.

6.5 EXTRAORDINARY MAINTENANCE

Immediate action must be taken in the event that a fault, malfunction or fluid leakage is reported by the operator or signalled by the general electrical panel, stopping the pump according to the shutdown procedure (see paragraph 5.7). The cause of the fault or malfunction must then be analysed (see paragraph 6.15). It is important to contact the manufacturer if the source or cause of the problem cannot be identified. No work must be carried out on the pump without prior approval from the manufacturer.

 In case of emergency or safety risk for the personnel can be used the emergency switch if a non-return device is included in the discharge piping.

 In the event of leakages of corrosive or hot liquid immediate actions to avoid the any contact, such as the evacuation of the area, must be taken. The corrosive liquid must be removed by authorized companies in accordance with national laws and regulations.

6.6 CRYSTALLIZATION OF THE PROCESS LIQUID

The user must analyse the characteristics contained in the data sheet of the liquid. In particular, the user must know the temperature and the starting conditions of the crystallization process and communicate them to the manufacturer of the pump. Failure to provide this information will invalidate the warranty of the pump unit.

6.7 DRAINING AND CHANGING THE PROCESS LIQUID

The pump manufacturer must be informed of any changing of liquid and will approve its use only after ensuring that it is compatible with the construction materials and that it will allow the good operation of the pump unit.

The procedure to be followed when changing the process liquid is as follows:

1. Stop the pump unit (see paragraph 5.7).
2. Drain completely the casing and the piping.
3. Clean the pump internally with water or a compatible liquid, taking care with regard to any chemical reactions.
4. Dispose of the rinsing liquid, with due care for the protection of the environment.

 In the event of leakages of corrosive or hot liquid immediate actions to avoid the any contact, such as the evacuation of the area, must be taken. The corrosive liquid must be removed by authorized companies in accordance with national laws and regulations.

 In case of leakage of not corrosive liquid provide immediate cleaning of the parts and the floor according to the safety recommendations.

6.8 DRY RUN OPERATION

The pumps of this series must never dry run in order to avoid premature wear or breakage of the rotary parts or the mechanical seal.

Below are listed situations in which dry run operation could occur:

- Total or partial absence of fluid in the suction tank.
- Failure to install or malfunction of the level probes.
- Inefficient maintenance of the filter or foot valve
- Failure to open the suction valve.
- Cavitation or air pockets generated by incorrect system configuration.

6.9 IMPURITIES CONTAINED IN THE PROCESS LIQUID

The process liquid should be clean. It is advisable not pumping liquids with percentages, even low, of solid particles. In case the liquid contains solids particles, the maximum concentration, size and hardness must be declared in the enquiry in order to allow the selection of the most suitable solution for the application.

NOTE: Solid particles increase the wear of the parts in contact with the process liquid.

NOTE: The concentration of solid particles must be limited through a suction filter properly sized.

NOTE: If solid particles are being pumped, it is recommended to have mechanical seal faces in Silicon Carbide.

NOTE: Slurry liquid pumping is not possible.

6.10 RECOMMENDED SPARE PARTS

The minimum quantity of spare parts should be determined considering working conditions and the number of interchangeable units. The pump manufacturer, on request, provide indications concerning the frequency of replacement for each single component.

The spare parts listed below are always needed in stock for each unit in operation:

Item	Description	Item	Description
210	Shaft	433	Mech. seal
230 or 233	Impeller	463 and/or 471	Seal housing
Kit	O-rings and gaskets	524	Shaft sleeve
		922	Impeller nut

TABLE 6.10.1: Recommended spare parts.

NOTE: Gaskets and O-rings must be replaced each time the pump or the single parts are disassembled for a maintenance operation.

To order spare parts should be provided:

- The serial number, name and type of pump (marked on the tag plate).
- Component position number (see parts list).
- Number of pieces required.

NOTE: **The spare parts must be provided exclusively by the pump manufacturer. The use of non-original spare parts will void the warranty and certifications relating to the entire group.**

NOTE: Spare parts must be kept in a dry, clean place, away from sources of vibration and at a temperature of between +5°C and +35°C.

6.11 DISPOSAL

All pump unit no more in use, as well as the single parts, must be differentiated and disposed according to their materials. Disposal must be carried out by specialized and authorized companies according to the laws and regulations in force.

6.12 RETURNING OF THE PUMP UNIT TO THE MANUFACTURER

Before returning the pump unit to repair in the manufacturer's factory the pump must be drained completely and cleaned internally with water or a compatible liquid, taking care with regard to any chemical reactions. Rinsing liquid should be disposed according national laws and local regulations.

! In case the above indications are not fulfilled the pump manufacturer can consider itself free to reject the goods received with shipping charges to the customer.

6.13 DISASSEMBLY OF THE PUMP UNIT

! **Do not try to disassemble or repair the pump unit without the assistance of the manufacturer. Disassembly procedure should only be performed by personnel in possession of at least basic mechanical knowledge and skills. Minimum knowledge of the materials used is also needed to provide a better understanding of the pump's characteristics.**

! The pump unit and its parts must never be adapted or modified without the manufacturer's authorization.

Follow the below procedure before removing the pump from the plant:

- Make sure that the pump unit is not in operation.
- Disconnect the plug from the electric board and the electric wires from the terminal board of the motor in order to avoid any unexpected start-up during the maintenance working. Carefully isolate the ends.
- Close the suction and discharge valves.
- Wait until the pump unit reaches the ambient temperature.
- Open the draining valve and clean the wet parts and the drip-pan of the baseplate (if provided) with water or appropriate liquid and dispose the pump washing solution according to laws and regulations in force.
- Remove the pump unit from the plant.

NOTE: Great care must be taken during the disassembly process to prevent damage to internal parts of the pump caused by the incorrect use of pliers and screwdrivers.

DISASSEMBLY PROCEDURE

NOTE: Place the various components on a bench in the same order in which they are removed and protect them from knocks and dust.

NOTE: Identify all parts and their codes before proceeding with disassembly.

! Pay attention during the disassembly procedure of the pump drainage and the drip pan of the baseplate (if provided). Remove traces or small quantity of liquid with care avoiding any leakage.

CAUTION The pump unit is composed of heavy components. Take care when removing them. The accidental fall of one of these components could create a serious danger for the operator as crushing of the fingers or other parts of the body. The components provided with hole or eyebolt (item 145, 146, 155 and 800) must be constantly connected to a lifting system to prevent their inadvertent moving from seats.

CAUTION Damaged or deteriorated tools could be dangerous. Use suitable and appropriate tools only.

NOTE: Single disassembly operations should be performed only if necessary.

1. Arrange all of the required tools on a bench:

- Belt wrench
- Curved-nose pliers for internal elastic ring
- Hexagon key
- Impeller extractor
- Key for internal hexagon socket screws
- Rubber mallet
- Straight-nose pliers for internal elastic ring
- T-handle key for external hexagon socket screws

2. Unscrew the Hexagon Socket head cap screws (item 914.6) from the Casing foot (item 157).



3. Unscrew the Hexagon Socket head cap screws (item 914.1a and 914.1b) from the Discharge flange (item 130).



4. Remove the Discharge flange (item 130).

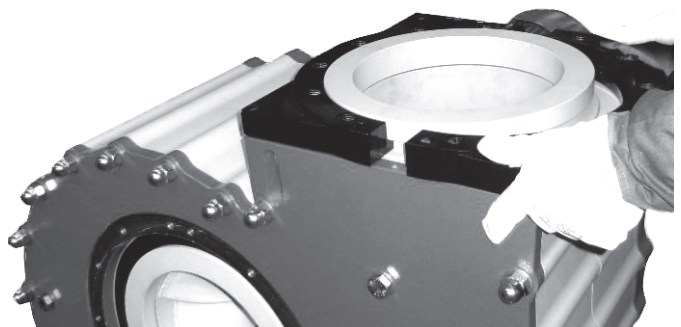

5. Remove the Discharge nozzle (item 152) and the Gasket (item 420.1).

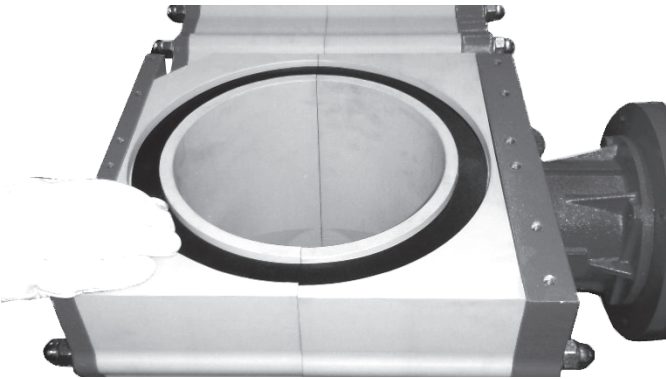

6. Remove the Casing screws (item 554.6, 902.3 and 921.1).

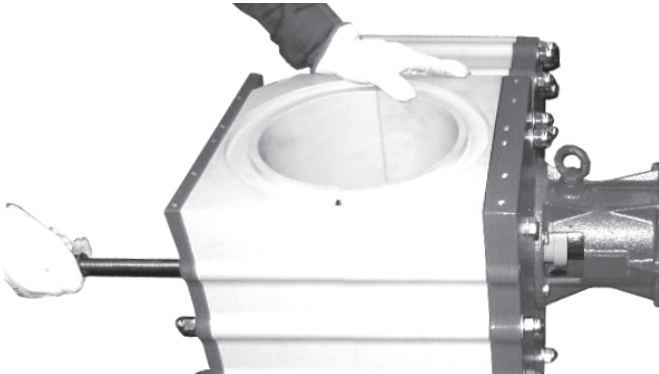

7. Remove the Front casing (item 101N) as a unique block with the Front armour (item 155) and Suction nozzle and flange (item 153 and 506). Only if necessary separate the single parts.

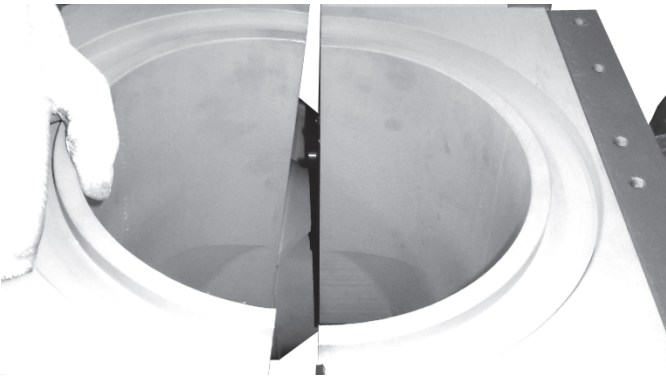

8. Unscrew the Impeller nut (item 922) by a Straight-nose pliers for internal elastic ring.

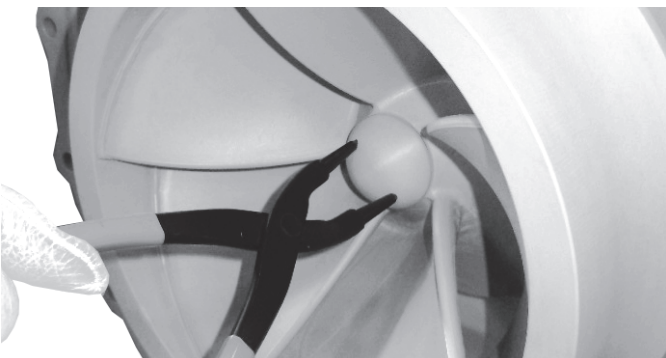

9. Unscrew the Hex nuts (item 920.3) by T-handle key for external hexagon socket screws.

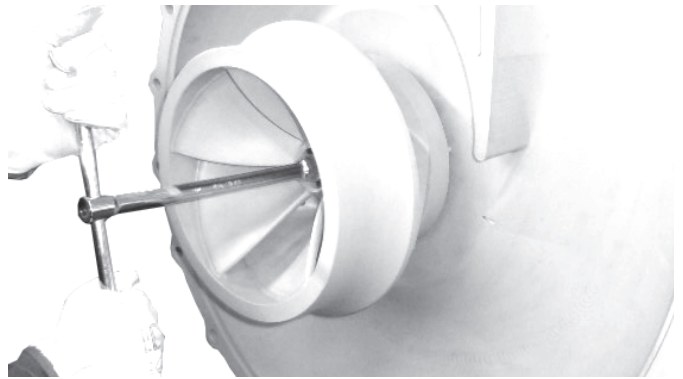

10. Remove the Washer (item 550) from the Impeller (item 230).

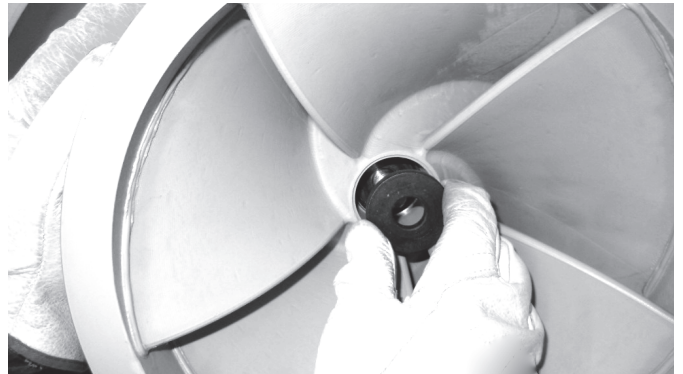

11. Remove the Impeller (item 230).



12. Remove the Gasket (item 400.1) from the Impeller (item 230).



13. Unscrew the Hex. screws (item 901.1b) of the Rear casing (item 101P).

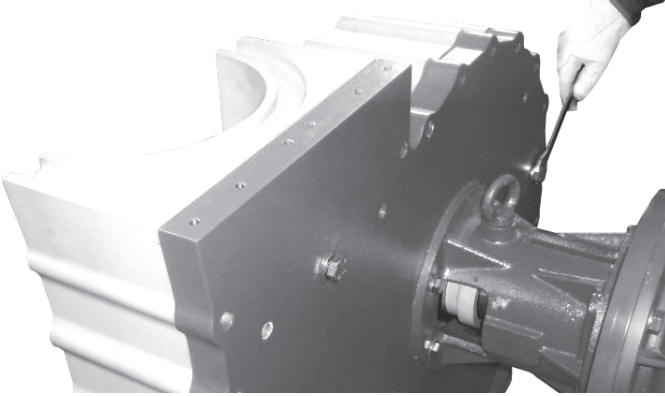

14. Remove the Rear casing (item 101P). For an easier extraction of the casing, tighten the Hex. screws (item 901.1).

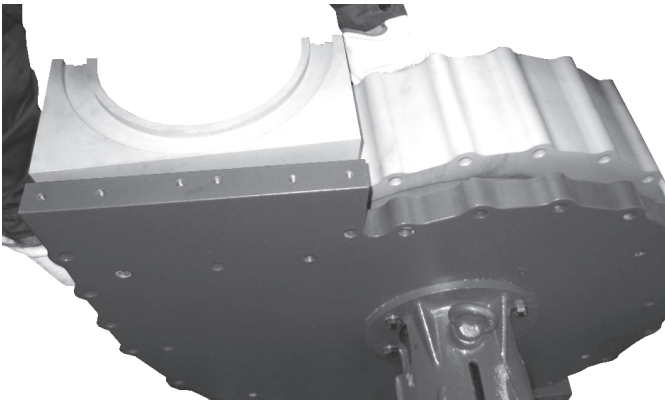

15. Unscrew the Seal housing screws (item 901.16).



MECHANICAL SEAL DISASSEMBLY (ONLY 10R TYPE)

16. Unscrew the screw of the Mechanical seal (item 475).

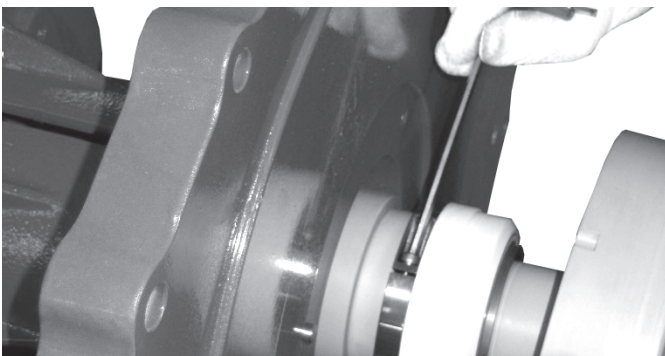

17. Remove the Mechanical seal block (item 433, 471, 490, 507, 524 and 525).

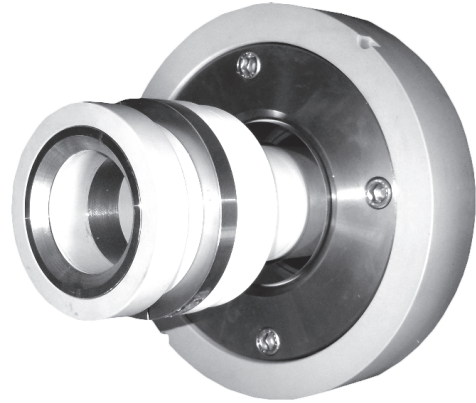

18. Unscrew the Retaining ring (item 490).



19. Check the Mechanical seal (item 433) and the other components.



MECHANICAL SEAL DISASSEMBLY (ONLY 2100 TYPE)

16. Remove the Seal housing (item 471) and the Mechanical seal block (item 433, 501, 507, 524, 525 and 528).



17. Disassembly the different parts of Mechanical seal block (item 433, 501, 507, 524, 525 and 528).





18. Remove the Mechanical seal ring (item 501) by Curved-nose pliers for internal elastic ring.



6.14 ASSEMBLY OF THE PUMP UNIT

 These operations must be carried out by qualified technical personnel.

 Any work must be carried out when the pump is not operating. If a switch is fitted, it must be set to the “zero” (off) position and disconnect the cables. A warning must be exposed on the control panel: **“Pump under repair: do not start”** and a warning must be exposed on the cables: **“Pump under repair: do not connect”**.

 **CAUTION** The pump unit is composed of heavy components. Take care when assembling them. The accidental fall of one of these components could create a serious danger for the operator as crushing of the fingers or other parts of the body. The components provided with hole or eyebolt (item 145, 146, 155 and 800) must be constantly connected to a lifting system after assembling them to prevent their inadvertent moving from seats.

NOTE: Considerable precision and care must be taken when performing the operations involved in the assembly procedure.

NOTE: Thoroughly clean any parts still in good condition using water or appropriate solvent (compatible with materials) before assembling.

NOTE: The assembly procedure should be carried out in a place free of dust and vibrations.

ASSEMBLY PROCEDURE

 All steps of the assembly procedure must be performed to make the pump unit complies with 2006/42/EC Machinery Directive.

 Use a dynamometric wrench to fasten all screws.

NOTE: Identify all of the parts and their codes on parts list before proceeding with assembly.

 **CAUTION** Damaged or deteriorated tools are dangerous. Use suitable and appropriate tools only.

The tightening torques (N/m) only for the pump assemblies are indicated here below:

Threading	Cast iron	Carbon Steel	Stainless Steel
	N/m	N/m	N/m
M8	6	8	7
M10	10	12	10
M12	14	17	15
M14	19	24	20
M16	26	32	27
M20	40	49	42
M24	57	71	60
M30	90	112	95

Table 6.14.1: Tightening torques in N/m.

NOTE: The values indicated above refer to new and intact fasteners.

NOTE: For the impeller nut (item 922) tightly tighten the screw manually by a Straight-nose pliers for internal elastic ring.

1. Arrange all of the assembly tools on a bench:

- Belt wrench
- Dynamometric wrench
- Hexagon key
- Key for internal hexagon socket screws
- Nipper
- Rubber mallet
- Straight-nose pliers
- T-handle key for external hexagon socket screws

2. Place the motor (item 800) on the base plate (item 890) and set fasteners (os. 554.7, 901.7 and 920.7).

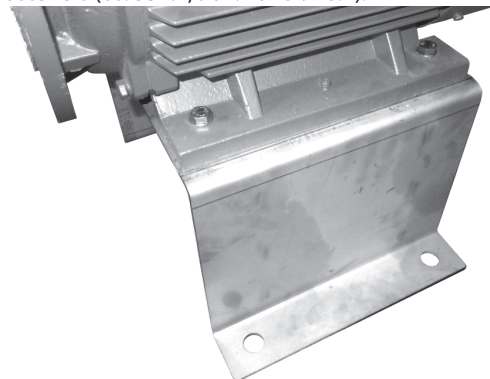

3. Insert the pump shaft (item 210) on the motor shaft (item 800). Grease the ends before insert.

4. Fix the pump shaft (item 210) by the socket set screws (item 904.1). Use a key for internal hexagon. Apply thread locker on the screws (item 904.1).

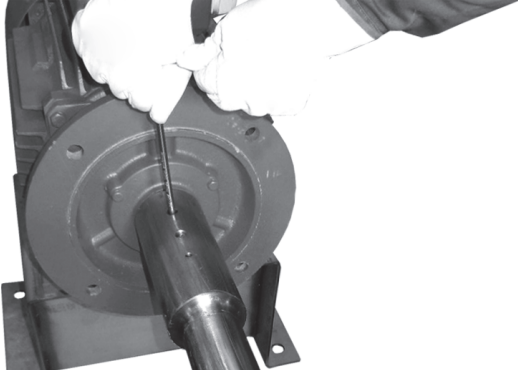

5. Verify the concentricity of the shaft (item 210) by a comparator during the manual rotation. The shaft run out should not exceed 0,05 mm.

6. Fix the adaptors (item 132, 145) to the intermediate lantern (item 146) by fastening (item 901.5, 554.5, 914.3).

7. Place the intermediate lantern (item 146).

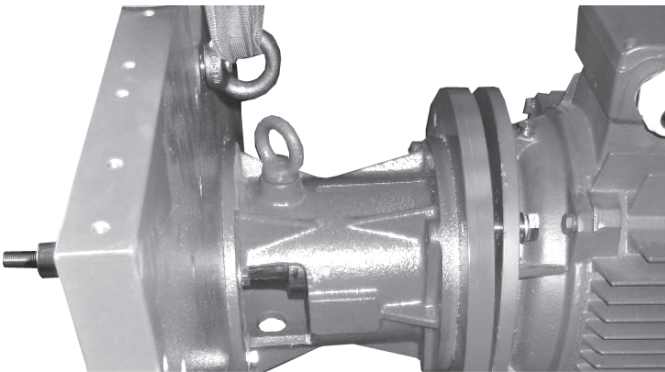

8. Fix the motor adaptor (item 132) by fasteners (item 901.3, 554.3).

MECHANICAL SEAL ASSEMBLY 10R TYPE JRS / JRS1 (ONLY 9÷17)

9. Place PTFE gasket (item 474) of the Mechanical seal on the Seal housing (item 471).

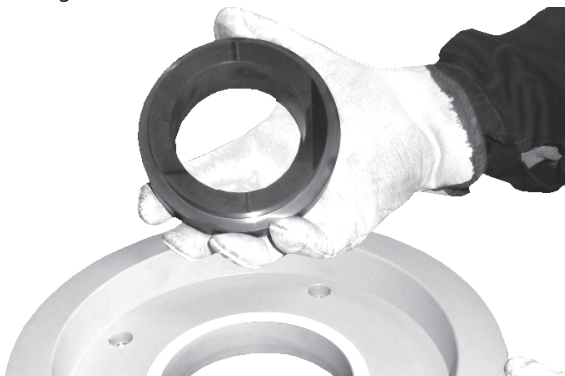

10. Place the Static ring (item 472) and the gasket (item 474) of the Mechanical seal with lapped face on the top.

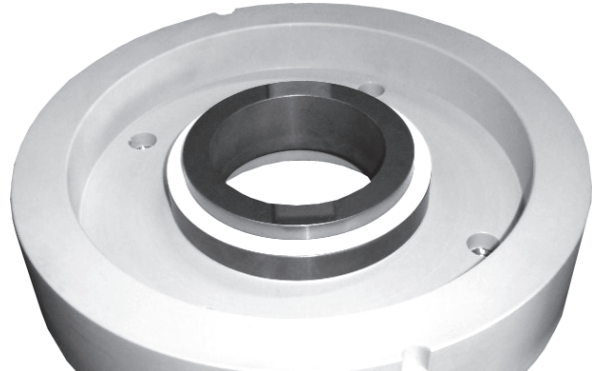

11. Fix the Seal flange (item 490). Apply 10 N/m diagonally.

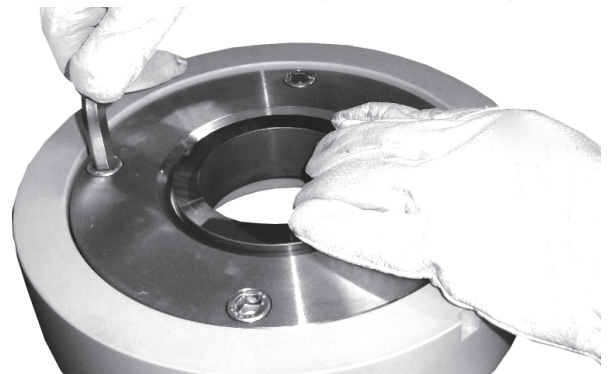

12. Insert the Shaft sleeve (item 524) in the Seal housing (item 471).

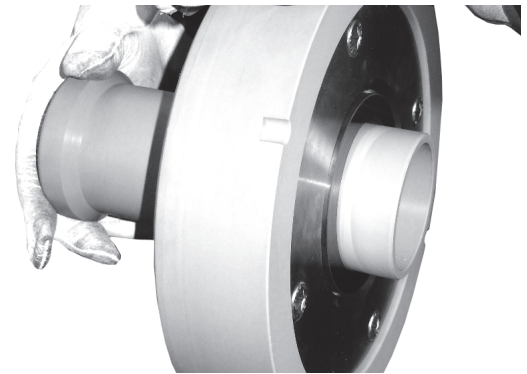

13. Place the O-ring (item 412.9) in the Deflector (item 507).

14. Set the Spacer (item 525) and the Deflector (item 507) using the Cylindrical pins (item 561.2).



15. Place the Mechanical seal (item 475).

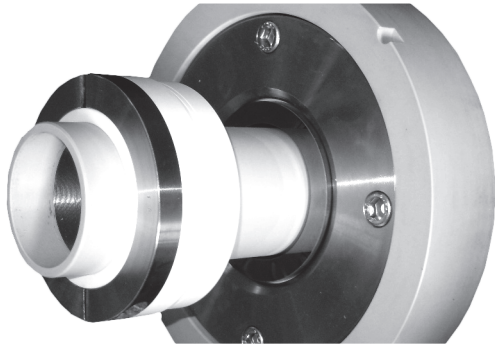

16. Place the Spacer (item 525) and the Deflector (item 507) on the Shaft sleeve (item 524).



- Set the static ring of the Mechanical seal (item 475) using a press. **ONLY FOR 2100 TYPE**

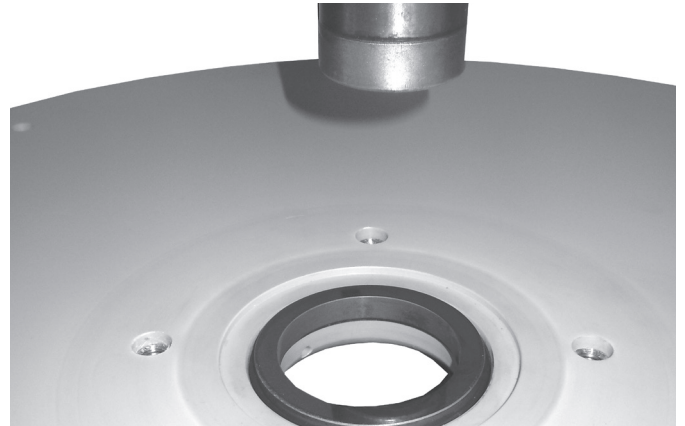

17. Insert the Mechanical seal block on the shaft (item 210) and fix the Mechanical seal screws by Key for internal hexagon socket screws.

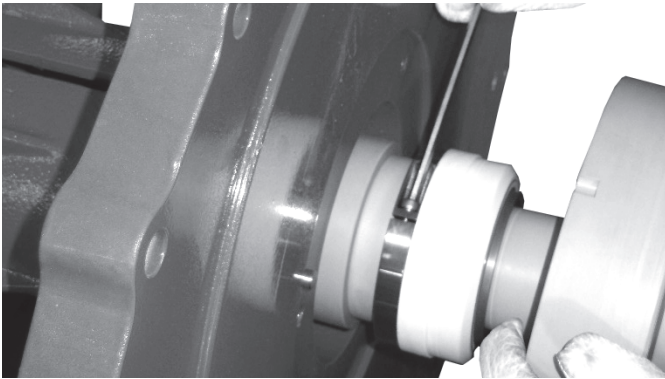

- Place the Mechanical seal (item 475). **ONLY FOR 2100 TYPE**

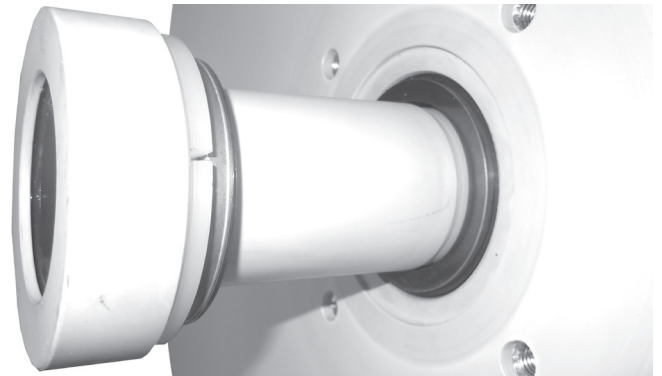

MECHANICAL SEAL ASSEMBLY 2100 TYPE B6E / B6EC

- Set the Mechanical seal ring (item 501) by Curved-nose pliers for internal elastic ring. **ONLY FOR 2100 TYPE**



- Place the Spacer (item 525) and the Deflector (item 507) on the Shaft sleeve (item 524). **ONLY FOR 2100 TYPE**



18. Set the Seal housing (item 471) by the Cylindrical pins (item 561.3) and fix it by the screws (901.16).

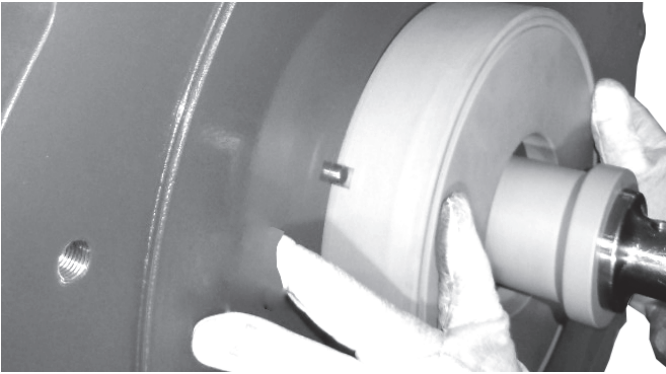

19. Place the O-ring (item 412.8) on the Seal housing (item 471).

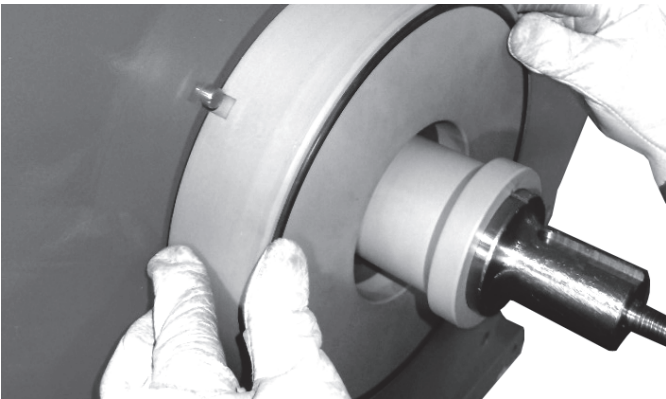

20. Place the Rear casing (item 101P).

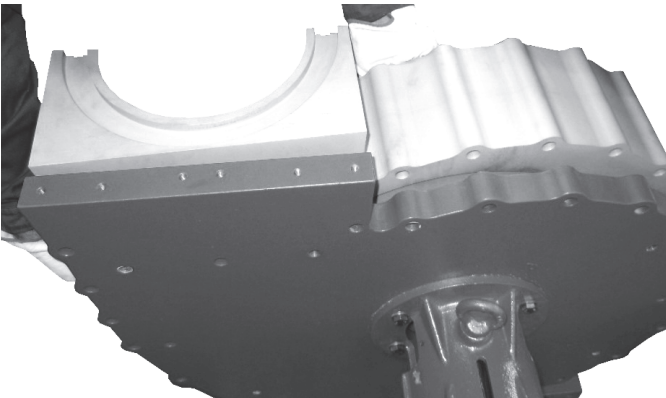

21. Fix the Rear casing (item 101P) by the screws (item 901.1b).

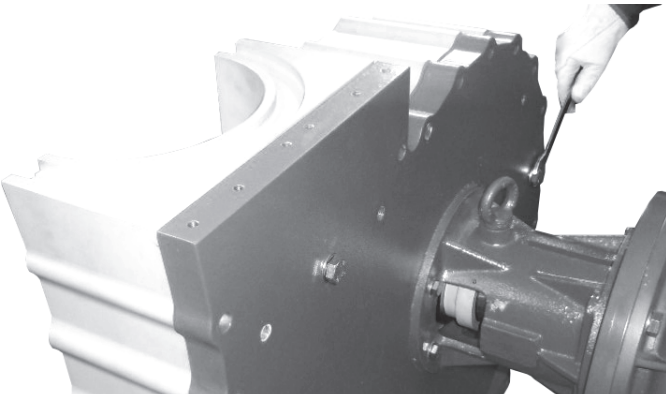

22. Set the two keys (item 940.1 and 940.3) on the shaft (item 210).

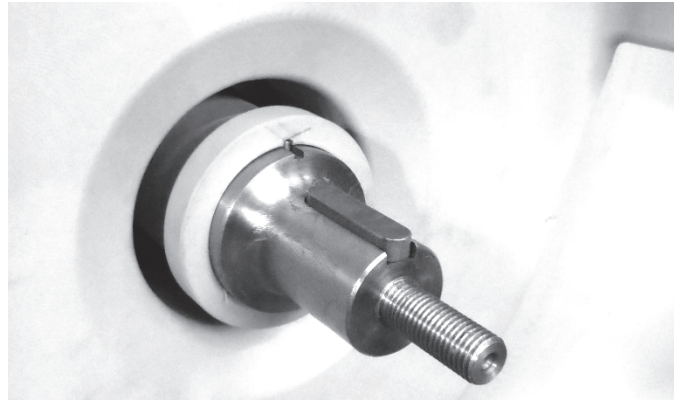

23. Place the Gasket (item 400.1) on the Impeller (item 230).



24. Place the Impeller (item 230) on the Shaft (item 210).

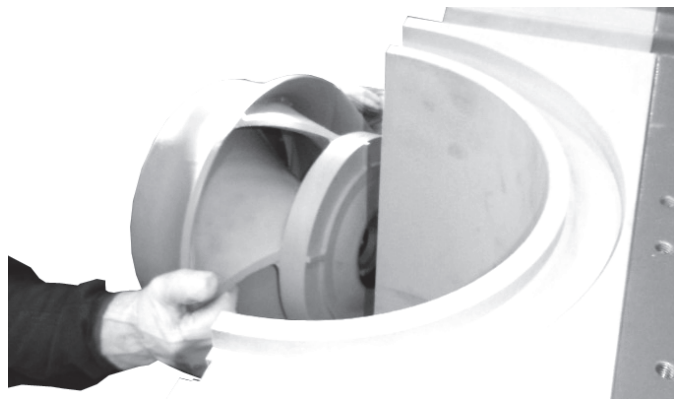

25. Insert the Washer (item 550) of the Impeller (item 230).

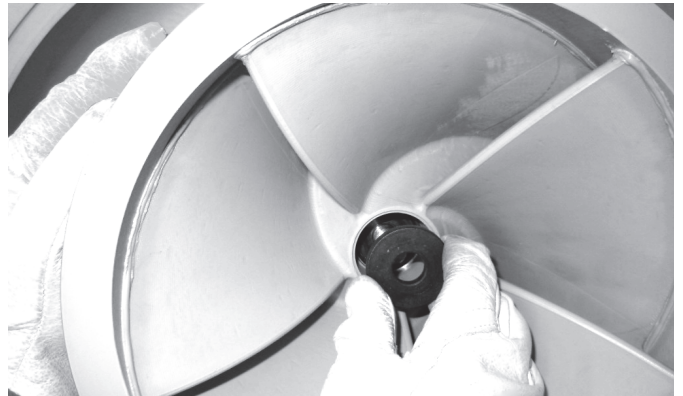

26. Set the two Hex nut (item 920.3) of the Impeller (item 230).

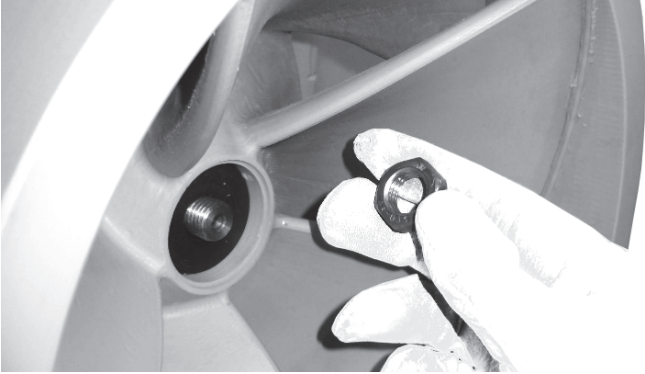

27. Fix the two Hex nut (item 920.3) of the Impeller (item 230) by T-handle key for external hexagon socket screws.

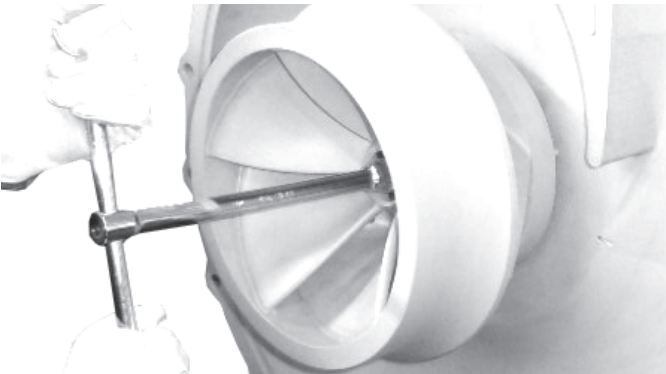

28. Place the O-ring (item 412.5) on the Impeller nut (item 922).



29. Screw the Impeller nut (item 922) by Straight-nose pliers for internal elastic ring.

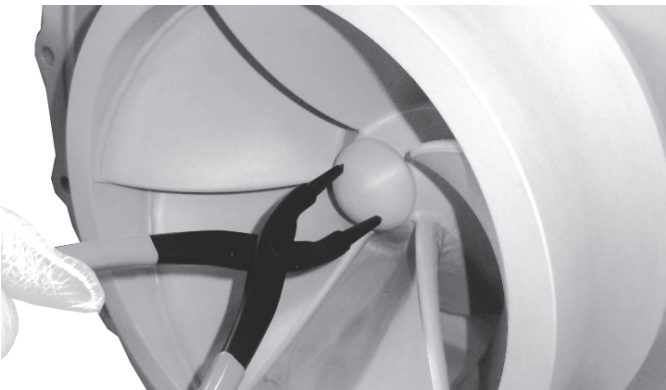

30. Place the Cylindrical pins (item 561.4) on the Casing (item 101P).



31. Place the Gasket (item 101G) between the two Casings (item 101A and 101P). Gasket should exceed 0.5 mm from the plane.

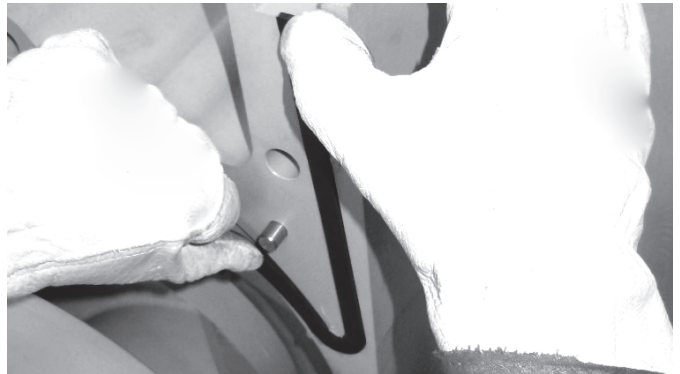

32. Set the Front armour (item 155) into the Casing (item 101A) and fix it by the screws (item 901.1b).

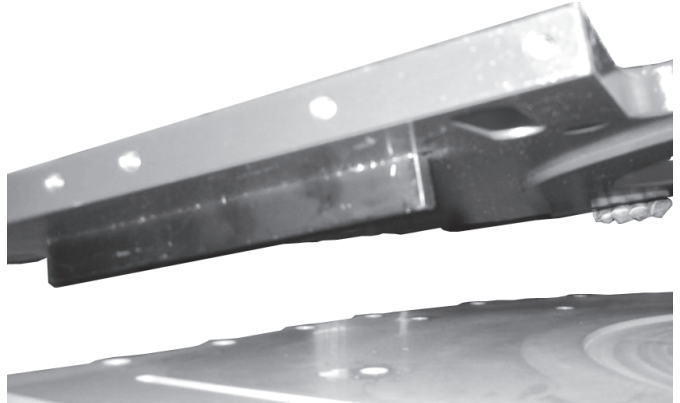

33. Set the Front casing (item 101P).

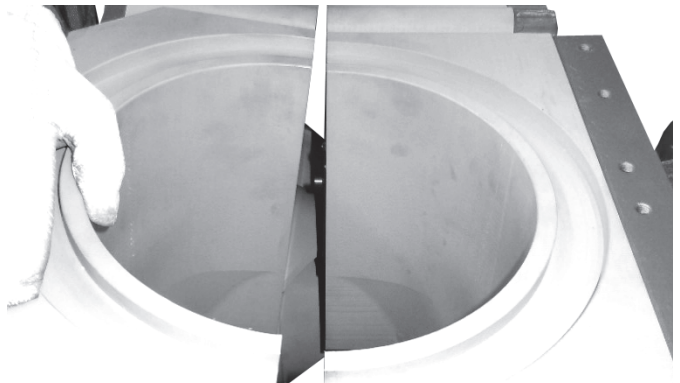

34. Only for new spare parts: cut the Gasket (item 400.1) exceeding from the Casing (item 101A and 101P) by a Nipper.



35. Set the fix Casing fastenings (item 901.1, 554.1 and 940.1).

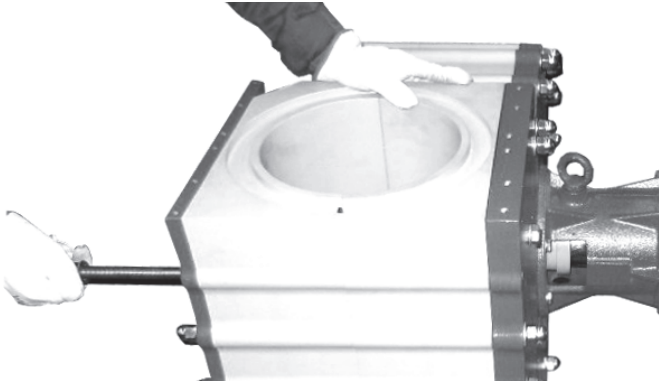

36. Place the Discharge flange gasket (item 920.1).

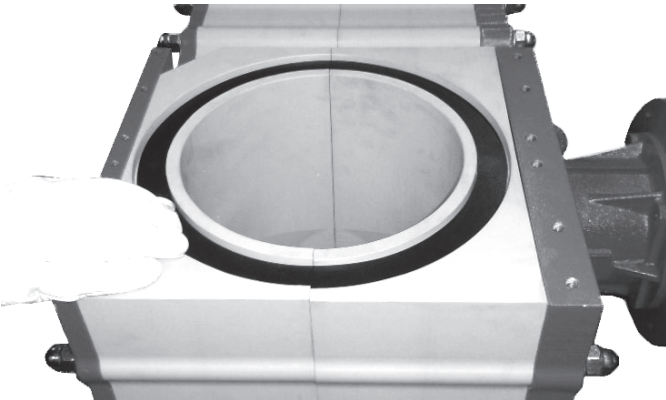

37. Insert the Discharge nozzle (item 152).



38. Place and fix the Discharge flange (item 130).

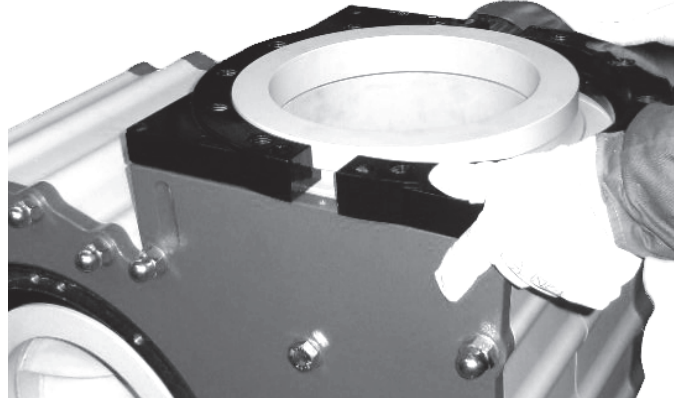

39. Place the Suction flange gasket (item 920.2).



40. Place and fix the Suction flange (item 230).

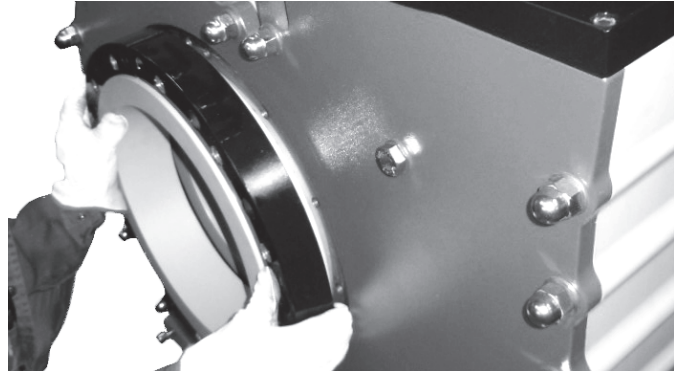

41. Set and fix the Casing foot (item 157) to Front and Rear armour (item 155 and 145).

42. Insert the Drainage nozzle (item 730) and the two O-rings (item 412.10).

43. Set the drainage flange (item 122A, 122B) and fix it by fasteners (item 554.4, 902.4, 920.4)

44. Tighten the stud bolts (item 902.1, 902.2) .

 Do not tighten the studs over the extension of the thread of the pump. Always check the depth of the tapped holes before tightening the studs.

6.15 CAUSES OF TROUBLE AND TROUBLESHOOTING

CAUSES	TROUBLESHOOTING
THE PUMP DOES NOT PUMPING	
Insufficient NPSHa	Check NSPHa is greater then NSPHr + 1 meter.
The end of the suction pipe or the foot valve are not submerged.	Submerge the end of the pipe or the foot valve at the recommended distance.
The caps on the suction and discharge ports have not been removed.	Remove the caps on the suction and discharge ports.
The gate valve in the suction pipe is closed or partially closed.	Open the gate valve completely.
Foreign bodies obstruct the impeller or the suction or discharge piping.	Remove the foreign bodies.
The impeller is worn or damaged or the distance between the impeller and the casing is greater than recommended.	Replace the impeller.
The discharge valve is closed.	Regulate the discharge valve according the declared duty point.
Two-phase motor operation.	Check the motor's electrical power supply.
The speed of rotation is low or the sense of rotation is wrong.	Check the wiring.
The frequency is not suitable for the pump.	Check the frequency.
IN SUCTION CONDITIONS THE PRIMING IS SLOW	
In the suction condition the foot valve is undersized, defective or dirty.	Check or replace the foot valve.
In the suction condition the suction lift exceed the pump ability.	Check the suction height is not higher than the pump limit or the level of liquid in the tank is not too low.
The suction pipe is too long or the diameter is too small.	Check the dimension of the suction pipe.
Air leaks in the suction piping.	Check the sealing condition and tightening between the connections on the suction piping.
The specific gravity, temperature or viscosity of the liquid are higher then design values.	Check the specific gravity, temperature and viscosity values.
INSUFFICIENT FLOW OR PRESSURE	
Air pockets are in the piping.	Check the piping conditions.
The process liquid contains air or gas.	Check the liquid conditions.
Foreign bodies obstruct the impeller or the suction or discharge piping.	Remove the foreign bodies.
The impeller is worn or damaged or the distance between the impeller and the casing is greater than recommended.	Replace the impeller.
Total head of the plant greater then the head provided by the pump.	Check hydraulic losses and condition of the plant.
The viscosity of the liquid is higher then design values.	Check the specific gravity, temperature and viscosity values.
The speed of rotation is low or the sense of rotation is wrong.	Check the wiring.
Wrong frequency.	Check the frequency.
PUMP VIBRATES EXCESSIVELY	
The pump cavitating.	Check the plant conditions and the causes of the cavitation.
Duty point outside the recommended flow rate.	Regulate the duty point according the recommended flow rate.
Foreign bodies obstruct the impeller or the suction or discharge piping.	Remove the foreign bodies.
One or some parts of the pump are damaged or worn.	Disassembly the pump and replace the damaged or worn parts.
Motor bearings are worn.	Replace the motor bearing.
The baseplate is not anchored firmly.	Anchor the baseplate firmly to a reinforced concrete base.
The anchor bolts are not tightened.	Tighten the anchor bolts.
THE MOTOR IS OVERHEATED	
The discharge valve is too open.	Regulate the discharge valve according the declared duty point.
The specific gravity or viscosity of the liquid are higher then design values.	Check the specific gravity and viscosity values.
The ambient temperature is too high.	Install the motor providing a minimum distance from other objects and supplying a proper ventilation.
The speed of rotation is high.	Check the wiring.
Excessive compression of the elastic element on the mechanical sealing.	Contact the manufacturer.
Motor bearings are defective.	Replace the motor bearings.
RAPID WEAR OF MECHANICAL SEAL	
The flushing or process liquid contains foreign bodies or abrasive substances.	Check that the percentage of solid particles does not exceed the maximum amount allowed for the application.
The materials of the mechanical seal are not compatible with the liquid.	Contact the manufacturer.
The process liquid contains air or gas.	Contact the manufacturer.
Duty point outside the recommended flow rate.	Regulate the duty point according the recommended flow rate.
Dry run operation.	Check the installation and operation of the pump.
RAPID WEAR OF THE MOTOR BEARINGS	
Duty point outside the recommended flow rate.	Regulate the duty point according the recommended flow rate.
Excessive thrust on the bearings caused by mechanical defects.	Contact the manufacturer.
Mechanical faults or damage to the pump.	Contact the manufacturer.

NOTE: Contact the manufacturer in case the failure reason has not been found.

7.0 PARTS LIST

7.1 SECTIONAL DRAWING AND PARTS LIST

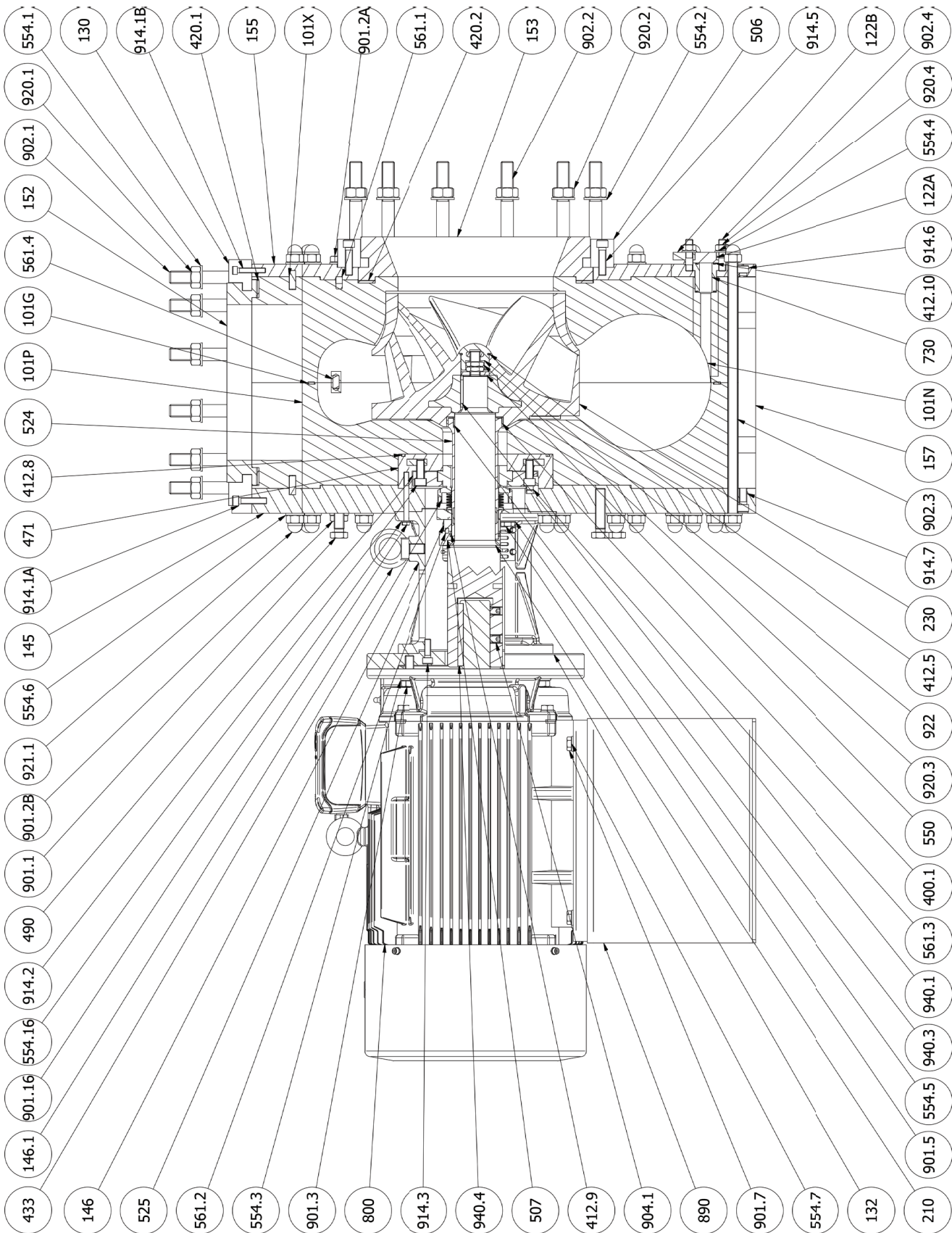

NOTE: Detailed information about the mechanical seal are given on pages 34÷39.

NOTE: Drawing available on request in A3, A2, A1 and A0 formats.

ITEM	QTY	DESCRIPTION	MATERIAL
554.7	8	Washer	SS 316
554.16	2	Washer	SS 316
561.1	1	Cylindrical pin	SS 316
561.2	2	Cylindrical pin	SS 316
561.3	2	Cylindrical pin	SS 316
561.4	3	Cylindrical pin	SS 316
730	1	Drainage nozzle	PPH, PVDF or PE-HD
800	1	Electric motor	Aluminium or Cast iron
890	1	Base	SS 316 or S235JR
901.1	5	Hex-Head Bolt	SS 316
901.2A	3	Hex-Head Bolt	SS 316
901.2B	3	Hex-Head Bolt	SS 316
901.3	4	Hex-Head Bolt	SS 316
901.5	4	Hex-Head Bolt	SS 316
901.7	4	Hex-Head Bolt	SS 316
901.16	2	Hex-Head Bolt	SS 316
902.1	12	Double End Stud	SS 316
902.2	12	Double End Stud	SS 316
902.3	21	Threaded rod	SS 316
902.4	4	Double End Stud	SS 316
904.1	2	Hexagon Socket Set Screw	SS 304
914.1A	6	Hexagon Socket Head Cap Screw	SS 316
914.1B	6	Hexagon Socket Head Cap Screw	SS 316
914.2	4	Hexagon Socket Head Cap Screw	SS 316
914.3	4	Hexagon Socket Head Cap Screw	SS 316
914.5	14	Hexagon Socket Head Cap Screw	SS 316
914.6	4	Hexagon Socket Head Cap Screw	SS 316
914.7	4	Hexagon Socket Head Cap Screw	SS 316
920.1	12	Hex Nut	SS 316
920.2	12	Hex Nut	SS 316
920.3	2	Hex Nut	SS 316
920.4	4	Hex Nut	SS 316
920.7	4	Hex Nut	SS 316
921.1	42	Hexagon Domed Cap Nuts	SS 316
922	1	Impeller nut	PPH, PVDF or PE-HD
940.1	1	Parallel Key	C45
940.3	1	Parallel Key	C45
940.4	1	Parallel Key	C45

ITEM	QTY	DESCRIPTION	MATERIAL
101G	1	Flat gasket	EPDM or FPM
101N	1	Front casing	PPH, PVDF or PE-UHMW
101P	1	Rear casing	PPH, PVDF or PE-UHMW
101X	2	Plate	S235JR
122A	1	Drainage protection	PPH, PVDF or PE-HD
122B	1	Drainage flange	PPH + Steel
130	1	Discharge flange	S235JR
132	1	Motor adaptor	S235JR
145	1	Frame adaptor	S235JR
146	1	Intermediate adaptor	Cast iron
146.1	1	Lifting Eyebolt	C15
152	1	Discharge nozzle	PPH, PVDF or PE-HD
153	1	Suction nozzle	PPH, PVDF or PE-HD
155	1	Front armour	S235JR
157	2	Casing foot	S235JR
210	1	Shaft	42CrMo4
230	1	Closed impeller	PPH, PVDF or PE-UHMW
400.1	1	Gasket	EPDM or FPM
412.5	1	O-ring	EPDM or FPM
412.8	1	O-ring	EPDM or FPM
412.9	1	O-ring	EPDM or FPM
412.10	2	O-ring	EPDM or FPM
420.1	1	Flat Gasket	EPDM or FPM
420.2	1	Flat Gasket	EPDM or FPM
433	1	Mechanical seal (10R Type)	SiC-SiC-PTFE
471	1	Seal chamber	PPH, PVDF or PE-HD
490	1	Retaining ring (10R Type)	SS 316
506	1	Suction flange	S235JR
507	1	Deflector	PPH
524	1	Shaft sleeve	PPH, PVDF or PE-HD
525	1	Spacer	PPH
550	1	Washer	SS 316 or 42CrMo4
554.1	12	Washer	SS 316
554.2	12	Washer	SS 316
554.3	4	Washer	SS 316
554.4	4	Washer	SS 316
554.5	4	Washer	SS 316
554.6	48	Washer	SS 316

7.2 EXPLODED VIEW AND PARTS LIST

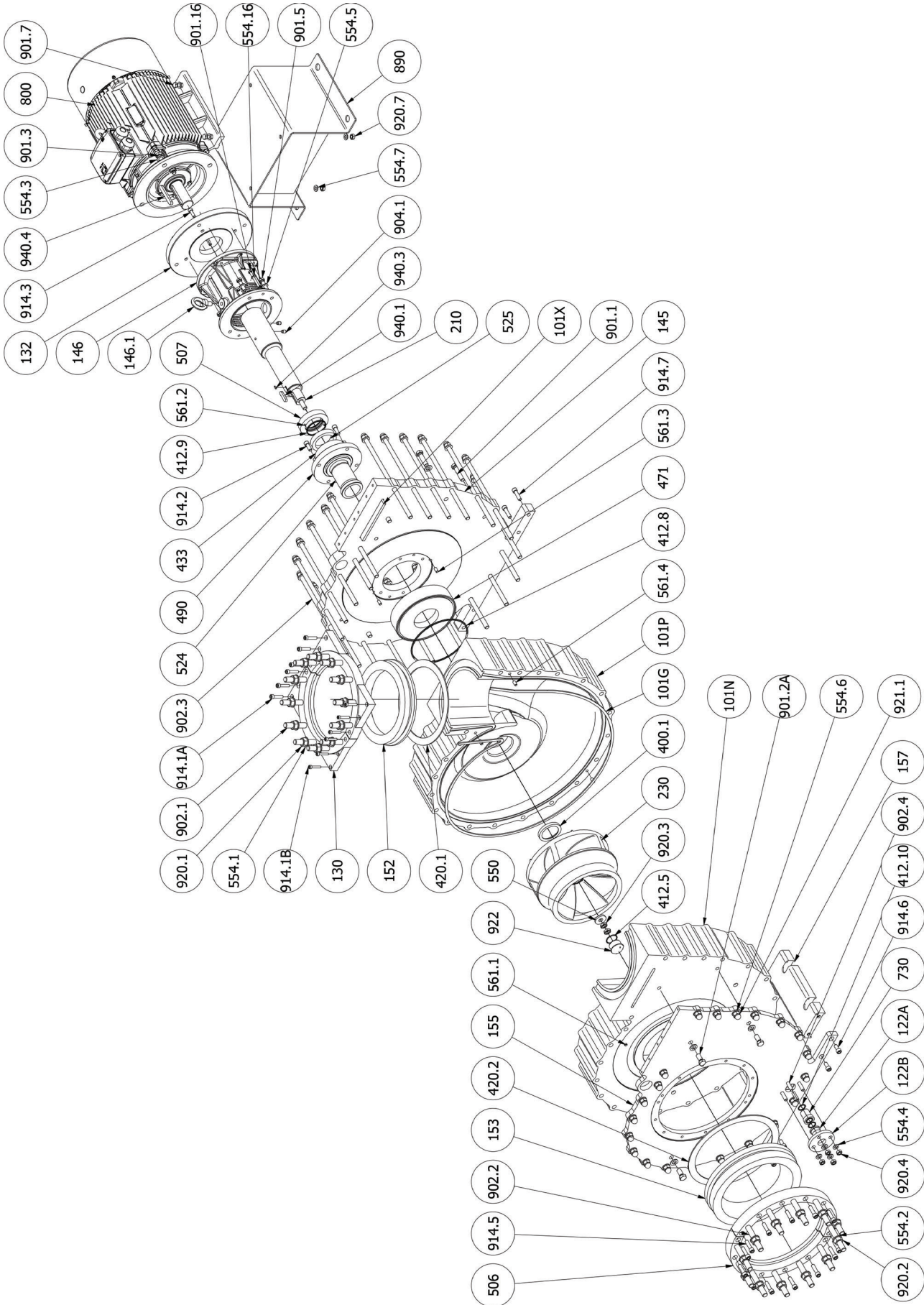

NOTE: Detailed information about the mechanical seal are given on pages 34÷39.

NOTE: Drawing available on request in A3, A2, A1 and A0 formats.

ITEM	QTY	DESCRIPTION	MATERIAL
554.7	8	Washer	SS 316
554.16	2	Washer	SS 316
561.1	1	Cylindrical pin	SS 316
561.2	2	Cylindrical pin	SS 316
561.3	2	Cylindrical pin	SS 316
561.4	3	Cylindrical pin	SS 316
730	1	Drainage nozzle	PPH, PVDF or PE-HD
800	1	Electric motor	Aluminium or Cast iron
890	1	Base	SS 316 or S235JR
901.1	5	Hex-Head Bolt	SS 316
901.2A	3	Hex-Head Bolt	SS 316
901.2B	3	Hex-Head Bolt	SS 316
901.3	4	Hex-Head Bolt	SS 316
901.5	4	Hex-Head Bolt	SS 316
901.7	4	Hex-Head Bolt	SS 316
901.16	2	Hex-Head Bolt	SS 316
902.1	12	Double End Stud	SS 316
902.2	12	Double End Stud	SS 316
902.3	21	Threaded rod	SS 316
902.4	4	Double End Stud	SS 316
904.1	2	Hexagon Socket Set Screw	SS 304
914.1A	6	Hexagon Socket Head Cap Screw	SS 316
914.1B	6	Hexagon Socket Head Cap Screw	SS 316
914.2	4	Hexagon Socket Head Cap Screw	SS 316
914.3	4	Hexagon Socket Head Cap Screw	SS 316
914.5	14	Hexagon Socket Head Cap Screw	SS 316
914.6	4	Hexagon Socket Head Cap Screw	SS 316
914.7	4	Hexagon Socket Head Cap Screw	SS 316
920.1	12	Hex Nut	SS 316
920.2	12	Hex Nut	SS 316
920.3	2	Hex Nut	SS 316
920.4	4	Hex Nut	SS 316
920.7	4	Hex Nut	SS 316
921.1	42	Hexagon Domed Cap Nuts	SS 316
922	1	Impeller nut	PPH, PVDF or PE-HD
940.1	1	Parallel Key	C45
940.3	1	Parallel Key	C45
940.4	1	Parallel Key	C45

ITEM	QTY	DESCRIPTION	MATERIAL
101G	1	Flat gasket	EPDM or FPM
101N	1	Front casing	PPH, PVDF or PE-UHMW
101P	1	Rear casing	PPH, PVDF or PE-UHMW
101X	2	Plate	S235JR
122A	1	Drainage protection	PPH, PVDF or PE-HD
122B	1	Drainage flange	PPH + Steel
130	1	Discharge flange	S235JR
132	1	Motor adaptor	S235JR
145	1	Frame adaptor	S235JR
146	1	Intermediate adaptor	Cast iron
146.1	1	Lifting Eyebolt	C15
152	1	Discharge nozzle	PPH, PVDF or PE-HD
153	1	Suction nozzle	PPH, PVDF or PE-HD
155	1	Front armour	S235JR
157	2	Casing foot	S235JR
210	1	Shaft	42CrMo4
230	1	Closed impeller	PPH, PVDF or PE-UHMW
400.1	1	Gasket	EPDM or FPM
412.5	1	O-ring	EPDM or FPM
412.8	1	O-ring	EPDM or FPM
412.9	1	O-ring	EPDM or FPM
412.10	2	O-ring	EPDM or FPM
420.1	1	Flat Gasket	EPDM or FPM
420.2	1	Flat Gasket	EPDM or FPM
433	1	Mechanical seal (10R Type)	SiC-SiC-PTFE
471	1	Seal chamber	PPH, PVDF or PE-HD
490	1	Retaining ring (10R Type)	SS 316
506	1	Suction flange	S235JR
507	1	Deflector	PPH
524	1	Shaft sleeve	PPH, PVDF or PE-HD
525	1	Spacer	PPH
550	1	Washer	SS 316 or 42CrMo4
554.1	12	Washer	SS 316
554.2	12	Washer	SS 316
554.3	4	Washer	SS 316
554.4	4	Washer	SS 316
554.5	4	Washer	SS 316
554.6	48	Washer	SS 316

7.3 MECHANICAL SEAL JRS / JRS1

The JRS / JRS1 type 10R is a single spring, PTFE bellows mechanical seal, designed for aggressive chemical service.

NOTE: If the mechanical seal is to be used for an application other than that originally intended or outside the recommended performance limits, the pump manufacturer must be contacted before its installation and use.

NOTE: Any warranty may be affected by improper handling, installation, or use of this mechanical seal.

Some important safety instruction are listed below:

- Installation and removal of the seal must be carried out only by qualified personnel who have read and understood this instruction manual.
- The seal is designed exclusively for sealing rotating shafts. The manufacturer cannot be held liable for use of the seal for purposes other than this.
- The seal must only be used in technically perfect condition and in conjunction with a suitable seat/mating ring, and must be operated within the recommended performance limits in accordance with its designated use and the instructions set out in this manual.
- If the process liquid is hazardous or toxic, appropriate precautions must be taken to ensure that any seal leakage is adequately contained. Further information on sealing hazardous or toxic fluids should be obtained from the pump manufacturer.

 PTFE components must never be incinerated or burned as their fumes and residues are highly toxic.

7.3.1 Configuration

The follow configurations is available:
- External mechanical seal JRS / JRS1

NOTE: Other configurations are available on request.

7.3.2 Installation

The seal must be installed to its correct working length L3. The green (JRS) or white (JRS1) indicator in the spring indicates the correct working length.

NOTE: For the assembly procedure see the paragraph 6.14.

 If L3 is overlength, the seal will be undercompressed and will leak; If L3 is underlength, the seal will be overcompressed and this will cause dry running and high wear of the seal faces.

 Allow at least 15 minutes to elapse between seal installation and pump commissioning to enable the seal to adjust to its working position.

7.3.3 Operation

Before operating the pump unit:

- Ensure that the seal gland screws are evenly tightened (10 N/m).
- Complete the assembly of the pump according the paragraph 6.14, and rotate the shaft head manually for at least 5 turns in the direction of rotation (via the fan of the drive) to prevent the contact faces from seizing up due to friction.

- Consult chapter 8 and all available equipment instruction manuals to check for correctness of all piping and connections, particularly seal recirculation/flush, heating or cooling requirements, and services external to the seal.
- Check that the seal chamber fluid lines are open and free of any obstruction, and ensure that the seal chamber is filled with fluid and fully vented.

 This mechanical seal is designed to operate in a liquid so that the heat energy it creates is adequately removed, and therefore the following check should be carried out, not only after seal installation, but also following a period of shut-down.

 Dry running often indicated by a squealing noise from the seal area will cause overheating and scoring or other damage to the sealing surfaces, resulting in excessive leakage or a much shortened seal life.

7.3.4 Shutdown

Follow all instruction contained in the paragraph 5.7.

After shutdown the pump unit:

- Ensure that the pump is electrically isolated.
- Ensure that the pump is isolated by the appropriate valves.
- Check that the fluid is drained and pressure is fully released.

 If the equipment has been used on toxic or hazardous fluids, ensure that the equipment is correctly decontaminated and made safe prior to commencing work. Remember, fluid is often trapped during draining and may be present inside the seal housing.

7.3.5 Maintenance

During operation, periodic inspection of the seal should be carried out. A measure of seal condition is the level of leakage, and as no maintenance is possible while installed, the seal should be replaced when leakage becomes unacceptable or when the external indicator shows more than 75% face/primary ring wear. It is recommended that a spare seal unit and seat/mating ring are held in stock to allow immediate replacement of a removed seal.

 Do not closely examine the seal for leakage when operating, without using suitable protection.

7.3.6 Removing the seal

In order to remove the seal follow the below instruction:

- Referring to the paragraph 6.13 dismantle the pump unit sufficiently to expose the seal chamber.
- Evenly slacken and remove the Retaining ring screws, and carefully slide the retaining ring (Item 490) off.
- Remove the seal housing (Item 471), clean and oil the shaft sleeve, and then complete the removal of the seal and the gland plate assembly in the reverse order to installation.

7.3.7 Parts list

ITEM	QTY	DESCRIPTION	MATERIAL
412.9	1	O-Ring	EPDM or FPM
472	1	Static ring	SiC
474	2	Gasket	PTFE
475	1	Rotating ring	SiC-PTFE-SS316
490	1	Retaining ring	SS 316
507	1	Deflector	PPH
524	1	Shaft sleeve	PPH, PVDF or PE-UHMW
525	1	Spacer	PPH
561.2	2	Cylindrical pin	SS 316
914.2	4	Cap screw	SS 316

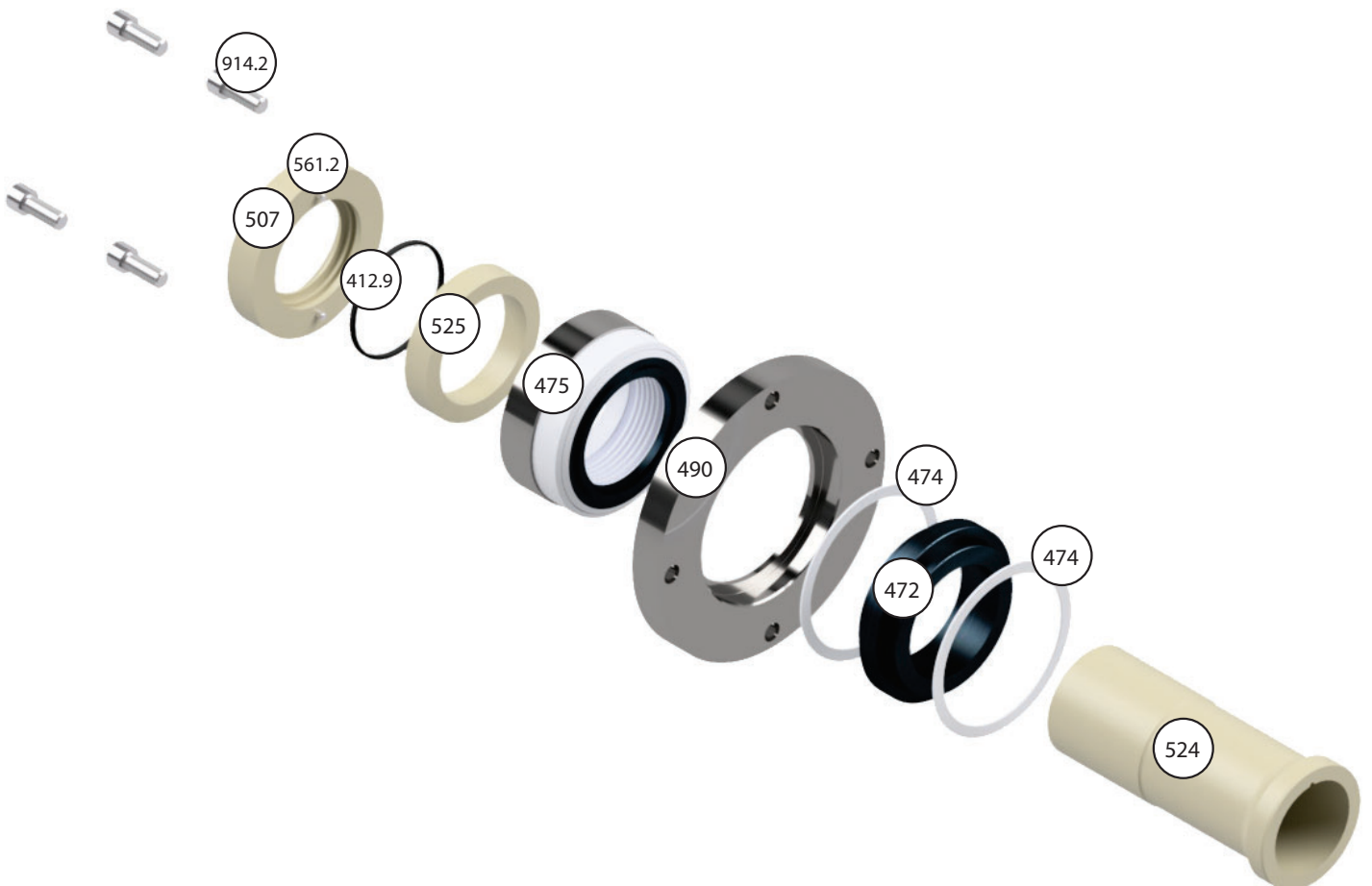
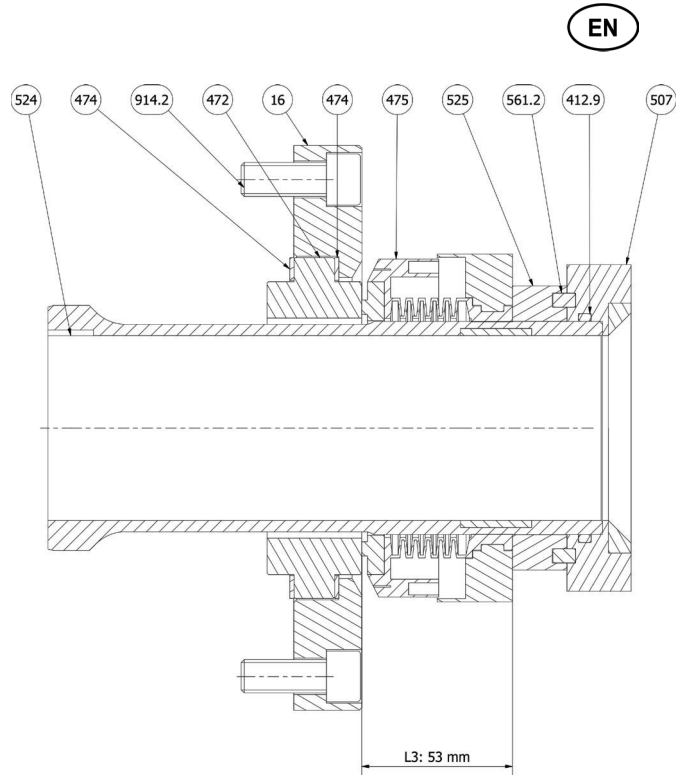

7.4 MECHANICAL SEAL B6E / B6EC / B6EFL / B6EFLC

The B6E / B6EC / B6EFL / B6EFLC type 2100 is a compact single spring, elastomeric bellows mechanical seal, designed for general applications and supplied in metric sizes (according to DIN 4960).

NOTE: If the mechanical seal is to be used for an application other than that originally intended or outside the recommended performance limits, the pump manufacturer must be contacted before its installation and use.

NOTE: Any warranty may be affected by improper handling, installation, or use of this mechanical seal.

Some important safety instruction are listed below:

- Installation and removal of the seal must be carried out only by qualified personnel who have read and understood this instruction manual.
- The seal is designed exclusively for sealing rotating shafts. The manufacturer cannot be held liable for use of the seal for purposes other than this.
- The seal must only be used in technically perfect condition and in conjunction with a suitable seat/mating ring, and must be operated within the recommended performance limits in accordance with its designated use and the instructions set out in this manual.
- If the process liquid is hazardous or toxic, appropriate precautions must be taken to ensure that any seal leakage is adequately contained. Further information on sealing hazardous or toxic fluids should be obtained from the pump manufacturer.

7.4.1 Configuration

The follow configurations are available:

- External mechanical seal B6E / B6EC
- External flushed mechanical seal B6EFL / B6EFLC

NOTE: The B6EFL / B6EFLC configuration requires an external flushing API PLAN 11, 12, 32 or similar. See chapter 8.

NOTE: Other configurations are available on request.

7.4.2 Installation

The seal must be installed to its correct working length L3.

NOTE: For the assembly procedure see the paragraph 6.14.

 If L3 is overlength, the seal will be undercompressed and will leak; if L3 is underlength, the seal will be overcompressed and this will cause dry running and high wear of the seal faces.

NOTE: It is essential to use a suitable lubricant when fitting the seal. The recommended lubricants for elastomeric bellows are soft hand soap and water, or glycerine; do not use washing-up liquid, liquid soaps, hand cleaning gels, oils or greases. Light mineral oil may be used sparingly with nitrile and fluorocarbon.

 Do not use hydrocarbon-based liquids on ethylene propylene bellows, and do not use grease (including silicone grease) on any elastomer bellows.

 Installation of the seal unit to its working length should be

complete within 15 minutes to ensure that the elastomer bellows is correctly positioned before the neck of the bellows permanently grips the shaft-sleeve.

7.4.3 Operation

Before operating the pump unit:

- Ensure that the seal gland nuts are evenly tightened according to the Table 6.14.1 torque setting.
- Complete the assembly of the pump according the paragraph 6.14, and rotate the shaft head manually for at least 5 turns in the direction of rotation (via the fan of the drive) to prevent the contact faces from seizing up due to friction
- Consult chapter 8 and all available equipment instruction manuals to check for correctness of all piping and connections, particularly seal recirculation/flush, heating or cooling requirements, and services external to the seal.
- Check that the seal chamber fluid lines are open and free of any obstruction, and ensure that the seal chamber is filled with fluid and fully vented.

 This mechanical seal is designed to operate in a liquid so that the heat energy it creates is adequately removed, and therefore the following check should be carried out, not only after seal installation, but also following a period of shut-down.

 Dry running often indicated by a squealing noise from the seal area will cause overheating and scoring or other damage to the sealing surfaces, resulting in excessive leakage or a much shortened seal life.

7.4.4 Shutdown

Follow all instruction contained in the paragraph 5.7.

After shutdown the pump unit:

- Ensure that the pump is electrically isolated.
- Ensure that the pump is isolated by the appropriate valves.
- Check that the fluid is drained and pressure is fully released.

 If the equipment has been used on toxic or hazardous fluids, ensure that the equipment is correctly decontaminated and made safe prior to commencing work. Remember, fluid is often trapped during draining and may exist outside the seal.

7.4.5 Maintenance

During operation, periodic inspection of the seal should be carried out. A measure of seal condition is the level of leakage, and as no maintenance is possible while installed, the seal should be replaced when leakage becomes unacceptable. It is recommended that a spare seal unit and seat/mating ring are held in stock to allow immediate replacement of a removed seal.

No maintenance of a seal is possible while installed.

7.4.6 Removing the seal

In order to remove the seal follow the below instruction:

- Referring to the paragraph 6.13 dismantle the pump unit sufficiently to expose the seal chamber.
- Evenly slacken and remove the seal chamber screws, and carefully slide the seal chamber (Item 463) off.
- Remove the seal housing (Item 471), clean and oil the shaft sleeve, and then complete the removal of the seal and the gland plate assembly in the reverse order to installation.

7.2.7 Parts list

ITEM	QTY	DESCRIPTION	MATERIAL
412.9	1	O-Ring	EPDM or FPM
412.11*	1	O-Ring	EPDM or FPM
433	1	Mechanical seal	SiC-SiC-SS316-EPDM or FPM
463*	1	Seal cover	PPH
501	1	Ring	PVDF
507	1	Deflector	PPH
524	1	Shaft sleeve	PPH, PVDF or PE-UHMW
525	1	Spacer	PPH
528	1	Collar	PPH
554.10*	4	Washer	SS 316
561.2	2	Cylindrical pin	SS 316
901.10*	4	Hex-Head Bolt	SS 316

* Only for B6EFL / B6EFLC configuration

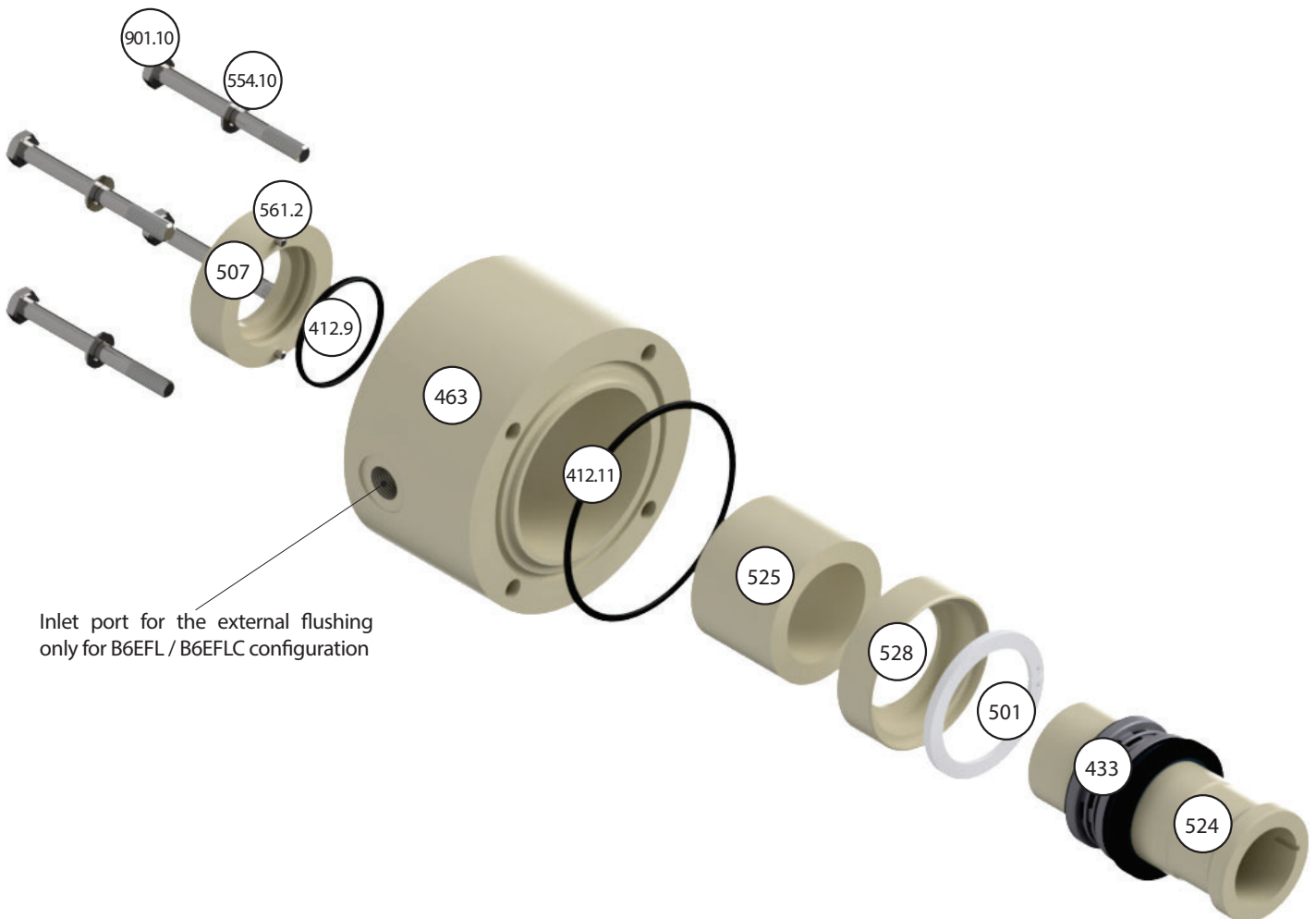
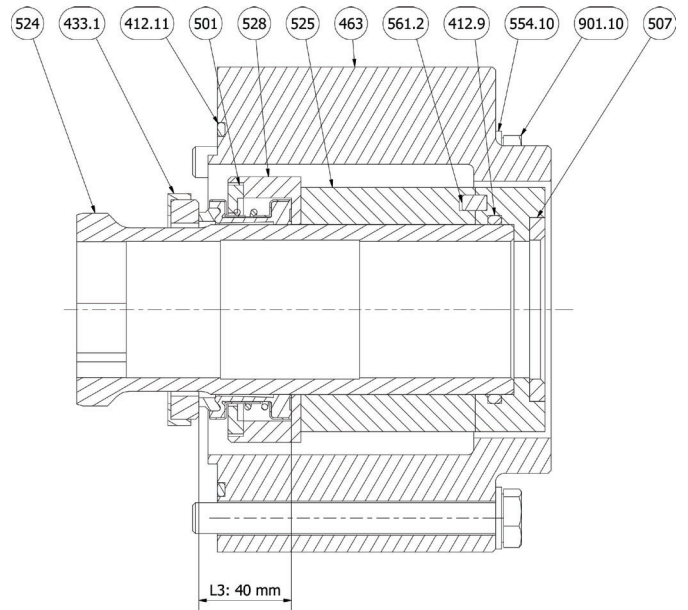

7.5 MECHANICAL SEAL B6EDF / B6EDFC

The double flushed B6EDF / B6EDFC type 2100 is a compact single spring, elastomeric bellows mechanical seal, designed for general applications and supplied in metric sizes (according to DIN 4960).

NOTE: If the mechanical seal is to be used for an application other than that originally intended or outside the recommended performance limits, the pump manufacturer must be contacted before its installation and use.

NOTE: Any warranty may be affected by improper handling, installation, or use of this mechanical seal.

Some important safety instruction are listed below:

- Installation and removal of the seal must be carried out only by qualified personnel who have read and understood this instruction manual.
- The seal is designed exclusively for sealing rotating shafts. The manufacturer cannot be held liable for use of the seal for purposes other than this.
- The seal must only be used in technically perfect condition and in conjunction with a suitable seat/mating ring, and must be operated within the recommended performance limits in accordance with its designated use and the instructions set out in this manual.
- If the process liquid is hazardous or toxic, appropriate precautions must be taken to ensure that any seal leakage is adequately contained. Further information on sealing hazardous or toxic fluids should be obtained from the pump manufacturer.

7.5.1 Configuration

The follow configurations is available:

- Double flushed mechanical seal B6EDF / B6EDFC

NOTE: The B6EDF / B6EDFC configuration requires a double seal flushing, like as API PLAN 52, 53, 54 or similar, combined with single seal flushing like as API PLAN 01, 11, 12, 32 or similar. See chapter 8.

NOTE: Other configurations are available on request.

7.5.2 Installation

The seal must be installed to its correct working length L3.

NOTE: For the assembly procedure see the paragraph 6.14.

 If L3 is overlength, the seal will be undercompressed and will leak; if L3 is underlength, the seal will be overcompressed and this will cause dry running and high wear of the seal faces.

NOTE: It is essential to use a suitable lubricant when fitting the seal. The recommended lubricants for elastomeric bellows are soft hand soap and water, or glycerine; do not use washing-up liquid, liquid soaps, hand cleaning gels, oils or greases. Light mineral oil may be used sparingly with nitrile and fluorocarbon.

 Do not use hydrocarbon-based liquids on ethylene propylene bellows, and do not use grease (including silicone grease) on any elastomer bellows.

 Installation of the seal unit to its working length should be

complete within 15 minutes to ensure that the elastomer bellows is correctly positioned before the neck of the bellows permanently grips the shaft-sleeve.

7.5.3 Operation

Before operating the pump unit:

- Ensure that the seal gland nuts are evenly tightened according to the Table 6.14.1 torque setting.
- Complete the assembly of the pump according the paragraph 6.14, and rotate the shaft head manually for at least 5 turns in the direction of rotation (via the fan of the drive) to prevent the contact faces from seizing up due to friction
- Consult chapter 8 and all available equipment instruction manuals to check for correctness of all piping and connections, particularly seal recirculation/flush, heating or cooling requirements, and services external to the seal.
- Check that the seal chamber fluid lines are open and free of any obstruction, and ensure that the seal chamber is filled with fluid and fully vented.

 This mechanical seal is designed to operate in a liquid so that the heat energy it creates is adequately removed, and therefore the following check should be carried out, not only after seal installation, but also following a period of shut-down.

 Dry running often indicated by a squealing noise from the seal area will cause overheating and scoring or other damage to the sealing surfaces, resulting in excessive leakage or a much shortened seal life.

7.5.4 Shutdown

Follow all instruction contained in the paragraph 5.7.

After shutdown the pump unit:

- Ensure that the pump is electrically isolated.
- Ensure that the pump is isolated by the appropriate valves.
- Check that the fluid is drained and pressure is fully released.

 If the equipment has been used on toxic or hazardous fluids, ensure that the equipment is correctly decontaminated and made safe prior to commencing work. Remember, fluid is often trapped during draining and may exist outside the seal.

7.5.5 Maintenance

During operation, periodic inspection of the seal should be carried out. A measure of seal condition is the level of leakage, and as no maintenance is possible while installed, the seal should be replaced when leakage becomes unacceptable. It is recommended that two spare seal units and seat/mating rings are held in stock to allow immediate replacement of a removed seal.

No maintenance of a seal is possible while installed.

7.3.6 Removing the seal

In order to remove the seal follow the below instruction:

- Referring to the paragraph 6.13 dismantle the pump unit sufficiently to expose the seal chamber.
- Evenly slacken and remove the seal chamber screws, and carefully slide the seal chamber (Item 463) off.
- Remove the seal housing (Item 471), clean and oil the shaft sleeve, and then complete the removal of the seal and the gland plate assembly in the reverse order to installation.





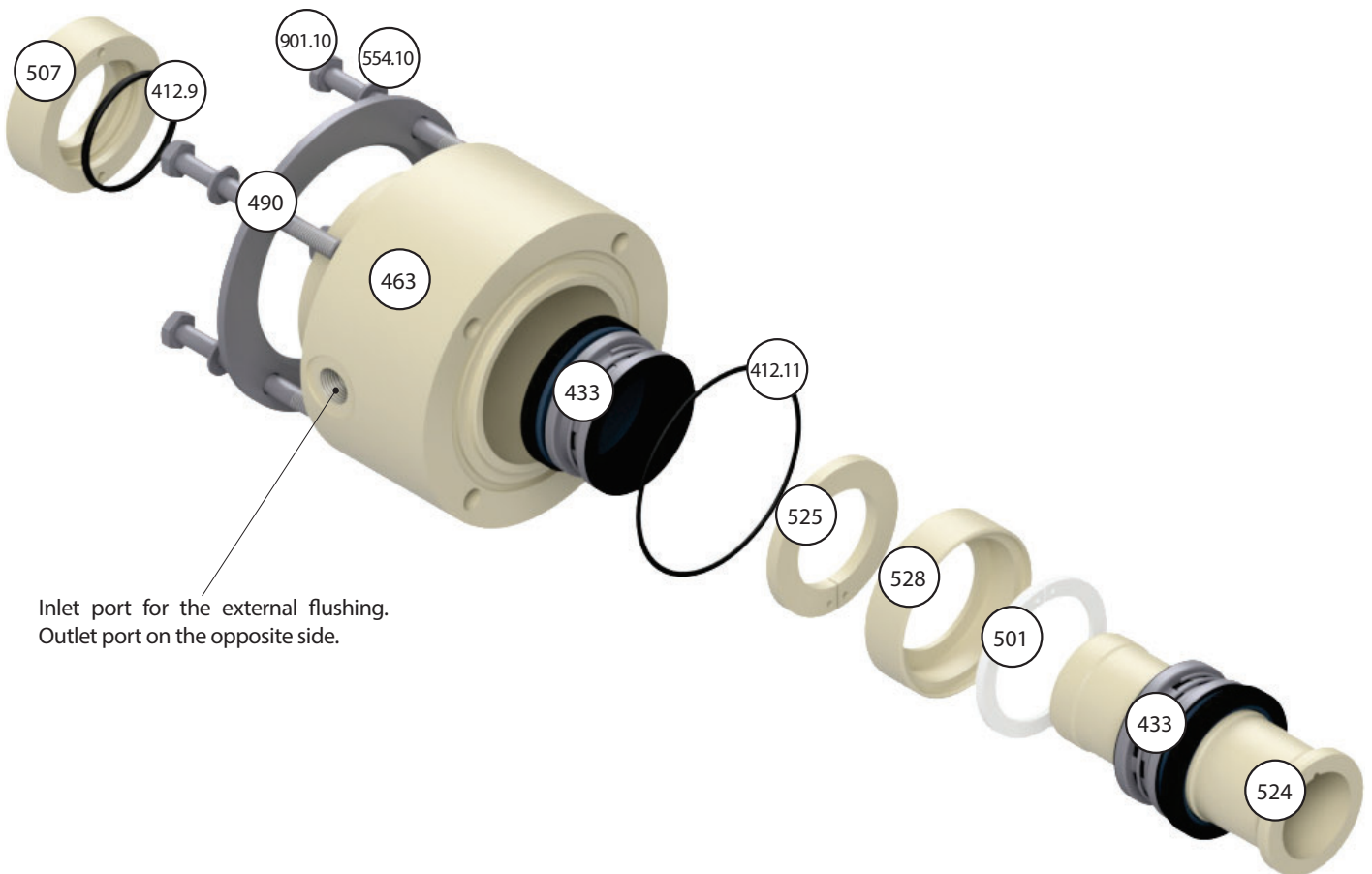
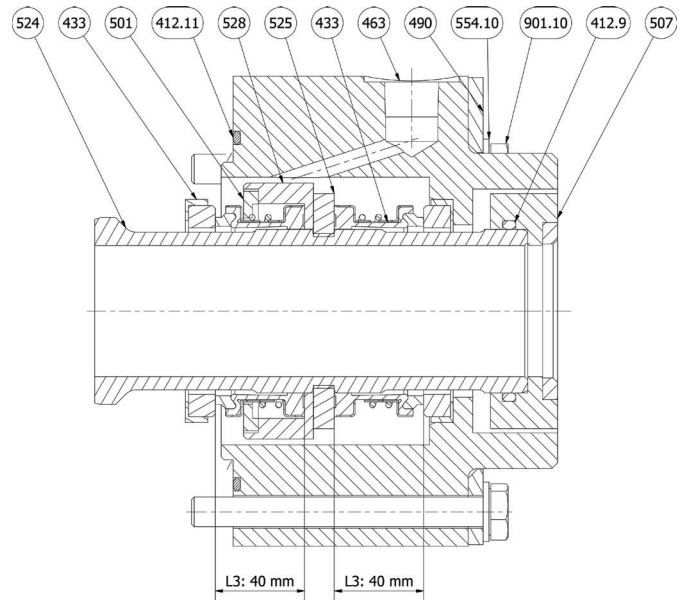







7.3.7 Parts list

ITEM	QTY	DESCRIPTION	MATERIAL
412.9	1	O-Ring	EPDM or FPM
412.11	1	O-Ring	EPDM or FPM
433	2	Mechanical seal	SiC-SiC-SS316-EPDM or FPM
463	1	Seal cover	PPH
490	1	Retaining ring	SS 316
501	1	Ring	PVDF
507	1	Deflector	PPH
524	1	Shaft sleeve	PPH, PVDF or PE-UHMW
525	1	Spacer	PPH
528	1	Collar	PPH
554.10*	4	Washer	SS 316
901.10*	4	Hex-Head Bolt	SS 316



8.0 AUXILIARY COMPONENTS

8.1 SYMBOLS LEGEND AND NOTES

SYMBOL	DESCRIPTION
	Inlet (auxiliary flushing)
	Outlet (auxiliary flushing)
	Manual control valve for pressure and flow rate adjustment
	Check valve
	Pressure and flow rate adjustment orifice
	Y filter
	Pressure indicator
	Temperature indicator
	Flow rate indicator
	Level indicator
	Pressure switch
	Level sensor

NOTE: A double seal API PLAN is always combined with a single seal API PLAN for examples 01+ 52, 12+53 or 32+54.

 The auxiliary flushing liquid should always be compatible with the process liquid and the construction materials of the wetted parts.

8.2 FLUSHING SYSTEM FOR SINGLE SEAL: API PLAN 01

DESCRIPTION: internal flushing system supplied as standard that allows process liquid from the pump casing to the seal to pass through an internal orifice.

USE: standard operating conditions, excluding the presence of solids and crystals and high temperatures.

BENEFITS: improves seal lubrication. Reduces the likelihood of the liquid freezing and reduces the temperature inside the gland. Does not entail prior calculation or additional cost.

DISADVANTAGES: cannot be used with dirty or excessively hot liquids. The quantity of liquid must always be checked to ensure that it is enough to cool the gland.

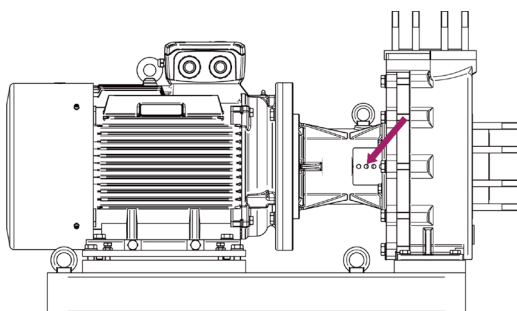

8.3 FLUSHING SYSTEM FOR SINGLE SEAL: API PLAN 11

DESCRIPTION: flushing system that recirculates process liquid from the discharge to the seal through an orifice for flow rate adjustment. **USE:** standard operating conditions, excluding the presence of solids, crystals and high temperatures.

BENEFITS: the liquid is injected at a higher pressure than that foreseen for API PLAN 01 improving flushing efficiency.

DISADVANTAGES: cannot be used with dirty or excessively hot liquids. The quantity of recirculating liquid must always be checked to ensure that it is enough to cool the gland. The recirculation flow rate and dimension of the orifice must be previously calculated.

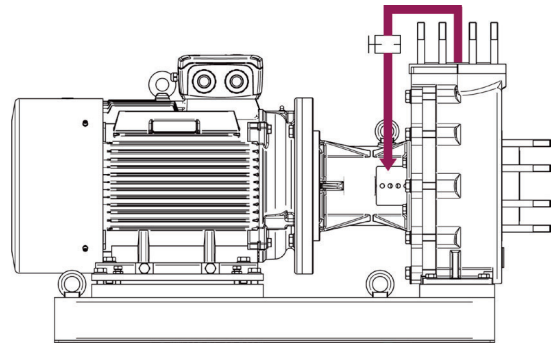

NOTE: The orifice must not be smaller than 1/8".

QUANTITY OF FLUSHING LIQUID

Seal Ø (mm)	< 1100 RPM	> 1100 RPM	Pressure
75	2 litres / min	3 litres / min	Operating pressure

8.4 FLUSHING SYSTEM FOR SINGLE SEAL: API PLAN 12

DESCRIPTION: flushing system that recirculates process liquid from the discharge to the seal through an orifice and a filter.

USE: standard operating conditions, excluding use with high temperatures. Recommended for low concentrations of solids or crystals. **BENEFITS:** the liquid is injected at a higher pressure than that foreseen for API PLAN 01 improving flushing efficiency. The filter reduces the presence of solids.

DISADVANTAGES: cannot be used with excessively dirty or hot liquids. The quantity of recirculating liquid must always be checked to ensure that it is enough to cool the gland. The recirculation flow rate and dimensions of the orifice and filter must be previously calculated.

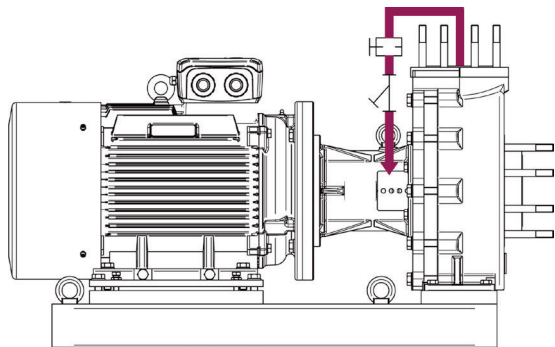

NOTE: The strainer must be cleaned periodically.

NOTE: The orifice must not be smaller than 1/8".

! Fluid leakages may occur during routine cleaning and replacement of the filter. These operations must be carried out when the pump is not in operation and using appropriate safety equipment.

QUANTITY OF FLUSHING LIQUID

Seal Ø (mm)	< 1100 RPM	> 1100 RPM	Pressure
75	2 litres / min	3 litres / min	Operating pressure

8.5 FLUSHING SYSTEM FOR SINGLE SEAL: API PLAN 32

DESCRIPTION: flushing system providing clean liquid from an external source with a temperature ranging from +10°C to +20°C.

USE: recommended for liquids containing high concentrations of solids or crystals and for high temperatures.

BENEFITS: the use of a flushing system with liquid from an external source extends the life of the mechanical seal, preventing it from leaking or breaking.

DISADVANTAGES: the auxiliary flushing liquid is fully dispersed in the process liquid (compatibility of the two liquids must be checked before use).

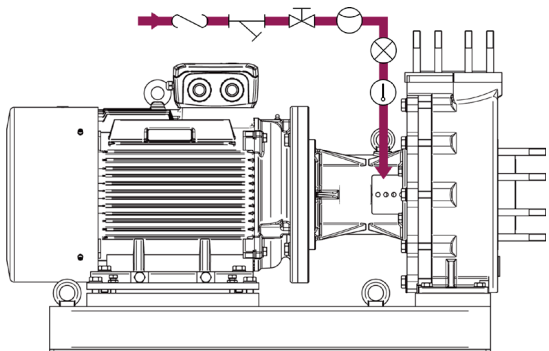

NOTE: The auxiliary liquid flow must be activated before the pump is started. It must remain continuous during all operation and can be interrupted only after the pumping unit is stopped.

QUANTITY OF FLUSHING LIQUID

Seal Ø (mm)	< 1100 RPM	> 1100 RPM	Pressure
75	2 litres / min	3 litres / min	1 Bar more than operating pressure

8.6 FLUSHING SYSTEM FOR DOUBLE SEAL: API PLAN 52

DESCRIPTION: a non-pressurised, external liquid tank sends clean, cold liquid (+10° / +20°C) to the seal using forced circulation provided by a thermosiphon effect or pumping system.

USE: recommended for process liquids containing high concentrations of solids or crystals and for high temperatures.

BENEFITS: recirculation of liquid through the tank prevents wastage of flushing liquid. It avoids dispersion of the auxiliary liquid into the process liquid.

DISADVANTAGES: the flushing circuit is complex.

Some installation instructions are given here below:

- Install the tank as close as possible to the pump. A distance of 30 to 45 cm from the shaft axis is recommended. Installation of the tank at a distance of more than a metre is not recommended.
- The capacity of the tank must be consistent with the size of the pump. The minimum capacity should be at least 4 litres for every 25 mm of diameter of the mechanical seal, maintaining a minimum quantity of 8 litres.
- Provide a liquid cooling circuit.

- Install a closure valve on both the OUTLET and INLET piping to the seal so that the tank can be isolated if the pipework needs replacing.
- Pipework should be preferably installed perpendicular to the gland (vertically). If horizontal installation is the only option, make sure that the flushing pipe running to the gland has a gradient of 1° to 5° to prevent air pockets.
- INLET piping running to the seal must have a minimum diameter of 3/4", whilst the OUTLET piping must have a minimum diameter of 1/2".
- Avoid elbows or tight bends along the short stretch of piping.
- Liquid contained within the tank must be topped up at a height of more than 25 mm above the maximum level of liquid contained therein.
- Fit an alarm system that activates a solenoid valve in the event of insufficient pressure inside the inlet piping.
- Provide a drainage hole for emptying the tank.

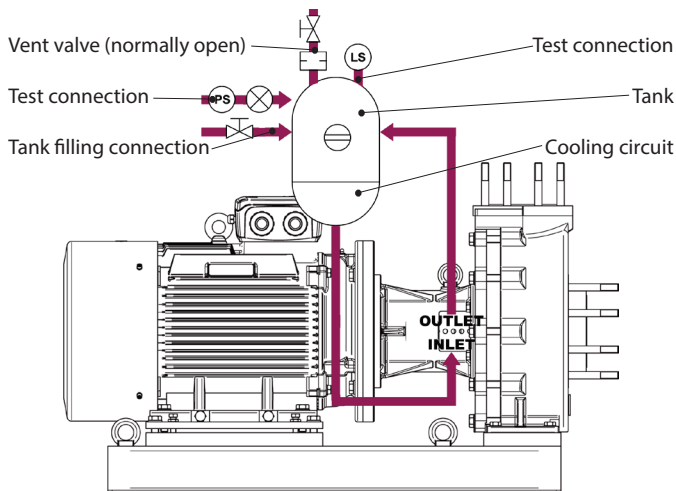

NOTE: The auxiliary liquid flow must be activated before the pump is started. It must remain continuous during all operation and can be interrupted only after the pumping unit is stopped.

! Vent the tank using a vent valve before start-up.

QUANTITY OF FLUSHING LIQUID

Seal Ø (mm)	< 1100 RPM	> 1100 RPM	Pressure
75	2 litres / min	3 litres / min	1 Bar more than operating pressure

8.7 FLUSHING SYSTEM FOR DOUBLE SEAL: API PLAN 53

DESCRIPTION: a pressurised, external liquid tank sends clean, cold liquid (+10° / +20°C) to the seal using forced circulation provided by a thermosiphon effect or pumping system.

USE: recommended for process liquids containing high concentrations of solids or crystals and for high temperatures.

BENEFITS: prevents the auxiliary liquid from becoming exposed to atmospheric pressure and guarantees zero emissions to the environment. A pressurised flushing system improves cleaning through the formation of a film between the surfaces of the seal rings.

DISADVANTAGES: the flushing circuit is complex and requires constant pressurisation. The auxiliary flushing liquid could become dispersed in the process liquid (compatibility of the two liquids must be checked). The pressurisation gas could dissolve in the auxiliary liquid. If the process liquid was dirty it could cause the flushing liquid to deteriorate, in which case it would have to be replaced regularly.

Some installation instructions are given here below:

- The tank must be as close as possible to the pump. A distance of 30 to 45 cm from the shaft axis is recommended. Installation of the tank at a distance of more than a metre is not recommended.
- The capacity of the tank must be consistent with the size of the pump. The minimum capacity should be at least 4 litres for every 25 mm of diameter of the pump shaft. Maintaining a minimum quantity of 8 litres.
- Provide a liquid cooling circuit.
- Install a closure valve on both the OUTLET and INLET piping running to the gland so that the tank can be isolated if the pipework needs replacing.
- Pipework should be installed perpendicular to the gland (vertically). If horizontal installation is the only option, make sure that the flushing pipe running to the gland has a gradient of 1° to 5° to prevent air pockets.
- INLET piping running to the seal must have a minimum piping diameter of 3/4", whilst the OUTLET piping must have a minimum diameter of 1/2".
- Avoid elbows or tight bends along the short stretch of piping.
- Liquid contained within the tank must be topped up at a height of more than 25 mm above the maximum level of liquid contained therein.
- Fit an alarm system that activates a solenoid valve in the event of insufficient pressure inside the inlet piping.
- Provide a drainage hole for emptying the tank.

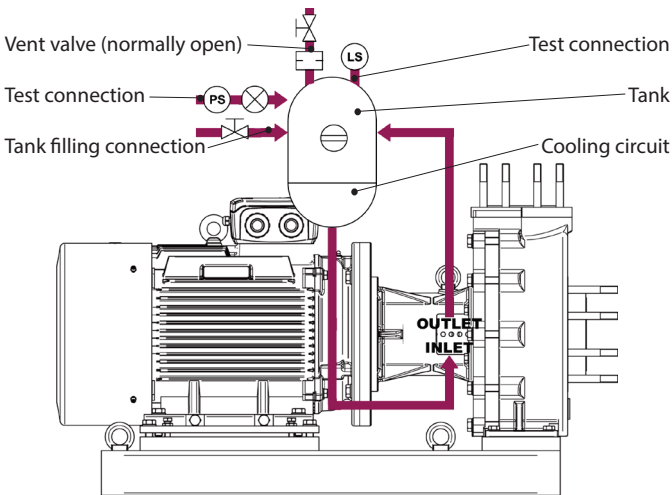

NOTE: The auxiliary liquid flow must be activated before the pump is started, it must remain continuous during all operation and can be interrupted only after the pumping unit is stopped.

 Vent the tank using a vent valve before start-up.

QUANTITY OF FLUSHING LIQUID

Seal Ø (mm)	< 1100 RPM	> 1100 RPM	Pressure
75	2 litres / min	3 litres / min	1 Bar more than operating pressure

8.8 FLUSHING SYSTEM FOR DOUBLE SEAL: API PLAN 54

DESCRIPTION: pressurised, external flushing system. Clean, cold liquid (+10° / +20°C) is circulated by an external pump or pressure system.
USE: recommended for process liquids containing high concentrations of solids or crystals, high temperatures or operating pressures.
BENEFITS: provides increased flow rate and greater heat dissipation.

There is no tank to size and manage and the flushing circuit is simple.
DISADVANTAGES: the flushing liquid could become dispersed in the process liquid (compatibility of the two liquids must be checked). If the process liquid was dirty it could cause the flushing liquid to deteriorate, in which case it would have to be replaced regularly. Liquid consumption could be high and costly.

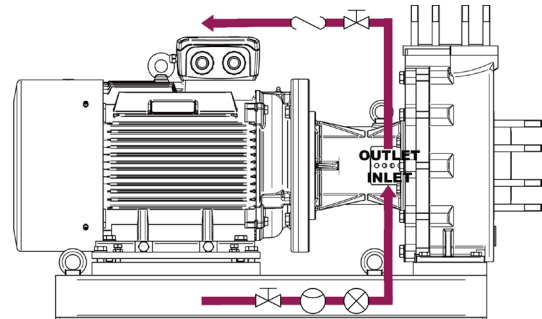

NOTE: The auxiliary liquid flow must be activated before the pump is started. It must remain continuous during all operation and can be interrupted only after the pumping unit is stopped.

QUANTITY OF FLUSHING LIQUID

Seal Ø (mm)	< 1100 RPM	> 1100 RPM	Pressure
75	2 litres / min	3 litres / min	1 Bar more than operating pressure

8.9 FLUSHING SYSTEM FOR DOUBLE SEAL: API PLAN 55

DESCRIPTION: unpressurised, external flushing system. Clean, cold liquid (+10° / +20°C) is circulated by an external pump or system.
USE: recommended for process liquids may solidify in contact with atmosphere, for high temperatures or operating pressures.
BENEFITS: provides greater heat dissipation. No liquid process deteriorating. No tank to size and manage and the flushing circuit is simple.
DISADVANTAGES: the process liquid could become dispersed in the flushing liquid (compatibility of the two liquids must be checked). The process liquid could cause the flushing liquid deteriorating, in which case it would have to be replaced regularly. Liquid consumption could be high and costly.

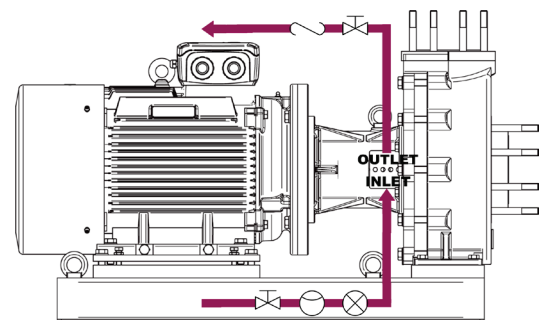

NOTE: The auxiliary liquid flow must be activated before the pump is started. It must remain continuous during all operation and can be interrupted only after the pumping unit is stopped.

QUANTITY OF FLUSHING LIQUID

Seal Ø (mm)	< 1100 RPM	> 1100 RPM	Pressure
75	2 litres / min	3 litres / min	Less than the seal chamber pressure

8.10 ADHESIVES AND ADDITIONAL INFORMATION

Adhesives and tag plates are applied to the pump unit. They contain safety measures and important indications to follow.



Adhesives and tag plates indicate safety measures. Non-observance of these instructions could pose a safety risk for people and the operation of equipment and could result in damage to the pump unit.

NOTE: All adhesives and tag plates must not be removed. If lost or illegible, they must be requested again to the pump manufacturer.

- The follow adhesive recalls the indispensable operations to be carried out before operating the pump unit.

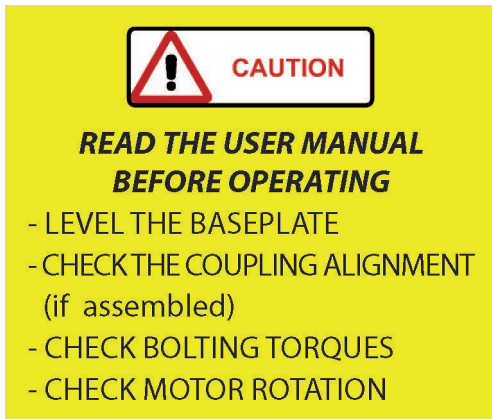

CAUTION

**READ THE USER MANUAL
BEFORE OPERATING**

- LEVEL THE BASEPLATE
- CHECK THE COUPLING ALIGNMENT (if assembled)
- CHECK BOLTING TORQUES
- CHECK MOTOR ROTATION

- The follow adhesive indicates that guards must not be removed during operation and that the pump unit must not be started without them.



WARNING

**DO NOT REMOVE GUARDS
OR OPERATE PUMP UNIT
WITHOUT THEM**

- The follow tag plate indicates the direction of rotation of the pump unit, clockwise looking from the motor to the pump.



- The follow adhesive indicates the inlet port of the external flushing. Here the user must install the piping connection to inject the auxiliary liquid. The adhesive can be found on all pumps with flushed or double mechanical seal. It is applied on the side of the seal chamber.

INLET

- The follow adhesive indicates the outlet port of the external flushing. Here the user must install the piping connection to eject the auxiliary liquid. The adhesive can be found on all pumps with double mechanical seal. It is applied on the side of the seal chamber.

OUTLET

- The follow adhesive indicates the drainage port. Can be found on all pumps with casing drainage, seal chamber and drip-tray. It is applied in the lowest part of the casing, on the bottom of the seal chamber for a single mechanical seal and close to the connection of the drip-tray.

DRAINAGE



COSTUMER FOCUSED



CARE IN RESEARCH & DESIGN



CUTTING-EDGE TECHNOLOGY

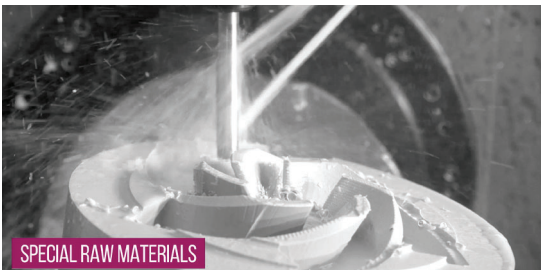

SPECIAL RAW MATERIALS



APPLICATION FIELD



FUNCTIONAL TESTING

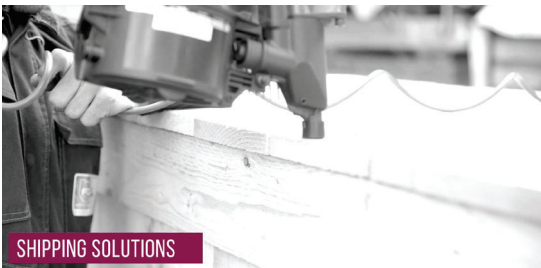

SHIPPING SOLUTIONS



AFFETTI PUMPS

YOUR SOLUTIONS

C O R R O S I V E A P P L I C A T I O N S

AFFETTI PUMPS s.r.l.
Via P. Maroncelli, 4
21053 CASTELLANZA (VA)

tel. (+39) 331-503358 (+39) 331-505595
fax. (+39) 331-483007
Sales Department: eaquila@affetti.com
Technical Department: mcassaniti@affetti.com
Web-site: www.affetti.com

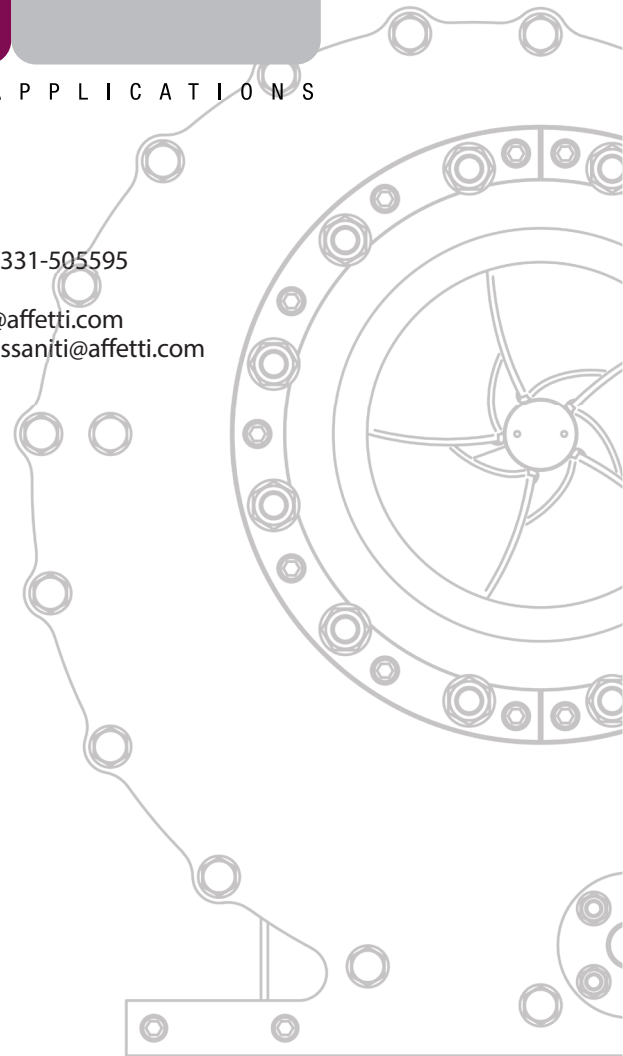

Technical modification reserved

Authorized distributor

All rights reserved. Reproduction, copying or transmittal of this manual and its contents are strictly prohibited without prior authorisation from the manufacturer.